



DOC026.52.00796

**si792(x) E—Hach GLI 3700 series
si792(x) T—7MA2200 and 8398 series**

**Inductive Conductivity
2-Wire Transmitter**

USER MANUAL

06/2016, Edition 8

Table of Contents

Section 1 Specifications	5
Section 2 General information	9
2.1 Safety information	9
2.1.1 Use of hazard information	9
2.1.2 Precautionary labels.....	9
2.2 General product information.....	11
2.2.1 Product overview.....	11
2.2.2 FDA 21 CFR part 11 compliance (HART only)	12
2.2.2.1 Electronic signatures for si792(x) E/T transmitters	12
2.2.2.2 Audit trail for si792(x) E/T transmitters.....	12
Section 3 Installation	13
3.1 Hazardous location installation.....	13
3.1.1 ATEX safety information	13
3.2 Unpacking the transmitter	14
3.3 Mechanical installation	15
3.3.1 Transmitter assembly.....	15
3.3.2 Mounting	15
3.3.2.1 Wall mount	15
3.3.2.2 Panel or pipe mount (optional).....	15
3.4 Wiring Safety Information.....	17
3.5 Electrical installation.....	18
3.5.1 Wire preparation.....	18
3.5.2 Power and communication connections.....	20
3.5.2.1 si792(x) E/T (4-20 mA/HART) wiring.....	21
3.5.2.2 si792x E/T-FF and si792x E/T-PA wiring	22
3.5.3 Sensor wire connections	22
3.5.3.1 Hach GLI 3700 series sensor wiring—si792(x) E	23
3.5.3.2 7MA2200 series sensor wiring—si792(x) T	24
3.5.3.3 8398 series sensor wiring—si792(x) T	25
3.6 HART communication connection	26
Section 4 Interface and navigation	27

Table of Contents

4.1	si792(x) E/T (4–20 mA/HART) interface.....	27
4.2	si792x E/T-FF and si792x E/T-PA interface	28
4.3	Display.....	29
Section 5 Operation—4–20 mA/HART		31
5.1	Measure mode	31
5.2	Configuration	31
5.2.1	Current output configuration.....	32
5.2.1.1	Time constant of output filter	35
5.2.1.2	Output signal during errors.....	35
5.2.1.3	Output signal during HOLD	36
5.2.2	Temperature compensation configuration.....	37
5.2.3	Alarm settings.....	38
Section 6 Operation—Foundation Fieldbus		39
6.1	Configuration	39
6.1.1	Configuration steps	39
6.1.2	Configuration menu	40
6.2	Foundation Fieldbus communication.....	43
6.2.1	Standard resource block (RB).....	43
6.2.2	Standard analog input block (AI).....	46
6.2.2.1	Operating modes.....	46
6.2.2.2	Set the parameter and units	46
6.2.2.3	Data processing	47
6.2.2.4	Alarms	47
6.2.2.5	Bus parameters for the analog input block.....	48
6.2.2.6	Cyclic measured value status.....	51
6.2.2.7	Measured value limits—limit bits.....	51
6.2.3	Transducer block.....	52
6.2.4	Calibration via Foundation Fieldbus	59
Section 7 Operation—Profibus PA.....		61
7.1	Configuration	61
7.1.1	Configuration steps	61
7.1.2	Configuration menu	62

Table of Contents

7.2 Profibus PA communication	63
Section 8 Calibration	67
8.1 Calibration	67
8.1.1 Enter cell constant.....	68
8.1.2 Calibration with a calibration solution.....	69
8.1.3 Calibration by comparison/grab sample.....	70
8.1.4 Zero calibration—air.....	71
8.1.5 Zero calibration—calibration solution.....	71
8.2 Temperature sensor adjustment	72
Section 9 Maintenance	73
9.1 Cleaning the instrument	73
9.2 Sensor maintenance	73
Section 10 Troubleshooting	75
10.1 Sensoface	75
10.2 Sensocheck.....	75
10.3 Error codes.....	76
10.4 Diagnostic tests.....	78
Section 11 Replacement parts	81
11.1 si792 transmitter versions	81
11.2 Accessories.....	81
11.3 Replacement parts	81
Appendix A Calibration solutions	83
Appendix B Concentration curves	87
B.1 Concentration measurement ranges.....	87
B.2 Sodium chloride solution -01- NaCl	89
B.3 Hydrochloric acid -02- HCl.....	90
B.4 Sodium hydroxide solution -03- NaOH	91
B.5 Sulfuric acid -04- H ₂ SO ₄	92
B.6 Nitric acid -05- HNO ₃	93
Appendix C Passcode editor	95
Appendix D ATEX safety instructions	97

Table of Contents

Index.....	101
------------	-----

Section 1 Specifications

Specifications are subject to change without notice.

Transmitter	
Composition	PBT (polybutylene terephthalate)
Display	LCD
Fittings	3 knockouts for M20 x 1.5 strain reliefs
	2 knockouts for ½ inch NPT or rigid metallic conduit
Power requirements—HART	14–30 VDC (30 VDC maximum)
Power requirements—FF and Profibus PA	FISCO bus supply: 9 to 17.5 VDC Linear barrier: 9 to 24 VDC
Loop current—HART	4–20 mA floating; 3.80–22.00 mA specifiable
Current consumption—FF and Profibus PA	< 13.2 mA
Maximum current in case of fault (FDE)—FF and Profibus PA	< 17.6 mA
Measurement error ²	<0.3% of current value + 0.05 mA
Certification (may not apply to all sensors. Refer to the control drawing or listing for certification information for the sensor that is used).	EU: si792x E/T ATEX Certification: II 2 (1) G Ex ib [ia Ga] IIC T6 Gb CE certified Enclosure: IP65
Output averaging time constant (HART)	0–120 seconds
Storage temperature	–20 to 70 °C (–4 to 158 °F)
Operating temperature	–20 to 55 °C (–4 to 131 °F)
Weight	Approximately 1 kg
Data retention	Parameters and calibration data > 10 years (EEPROM)
Passcodes	Modifiable according to FDA 21 CFR Part 11 “Electronic Signatures” (HART only)

Specifications

Sensocheck	Monitoring of primary coil and its lines for short circuit and of secondary and its lines for open circuit
Sensor monitor	Direct display of measured values from sensor for validation (resistance/temperature)
Communication¹	
HART communication	Digital communication by FSK modulation of loop current, reading of device identification, measured values, status and messages, reading and writing of parameters, start of product calibration, signaling of configuration changes according to FDA 21 CFR Part 11.
Foundation Fieldbus (FF_H1)	Bus-powered device with constant current consumption. Cyclic and acyclic data exchange. 1 resource block, 1 transducer block, 3 analog input function blocks (switchable: conductivity, concentration, salinity, temperature, cell constant)
	Execution time: 50 ms
	Certified to ITK 4.6
	Physical interface: to IEC 1158-2
	Address range: 017 to 246

Specifications

Profibus-PA (DPV1)	Bus-powered device with constant current consumption. Cyclic and acyclic data exchange. Physical block, 2 analog input function blocks, 2 discrete input blocks, logbook block, alarm block.
	PNO directive: PROFIBUS-PA, Profile for Process Control Devices, Version 3.0
	Physical interface: MBP-IS (Manchester Bus Powered-Intrinsically Safe) to IEC 1158-2 (DIN-EN 61158-2)
	Connection: via segment coupler to DCS, PC, PC
	Address range: 1 to 126
Conductivity input	
Electrodeless conductivity sensors, ranges	7MA2200 series
	8398 series
	Hach 3700 series
	Conductivity 0.00–1999 mS/cm
	Concentration 0–100% by weight
	Salinity 0.0–45 ‰ (0–35 °C)
Range, conductivity	0.000–9.999 mS/cm
	00.00–99.99 mS/cm
	000.0–999.9 mS/cm
	0–1999 mS/m
	0.000–9.999 S/m
	00.00–99.99 S/m
Range, concentration	0.00–100.0% by weight
Range, salinity	0.0–45 ‰ (0–35 °C)
Measurement error	< 1% measured value + 0.02 mS/cm
Temperature input	
Sensor	Pt100/PT1000/NTC 30 k Ω /NTC 100 k Ω 2-wire connection

Specifications

Range, Pt100/Pt1000	-20.0 to 200.0 °C (-4 to 392 °F)
Range, NTC 30 kΩ	-20.0 to 150.0 °C (-4 to 302 °F)
Range, NTC 100 kΩ	-20.0 to 130.0 °C (-4 to 266 °F)
Adjustment range	10 K
Resolution	0.1 °C; 0.1 °F
Measurement error ^{2,3}	< 0.5 K (< 1 K for Pt100;<1 K for NTC >100 °C)

¹ Foundation Fieldbus and Profibus are no longer available. The wiring information for the Foundation Fieldbus and Profibus is supplied as historical data only.

² (± 1 count plus sensor error)

³ IEC 746 Part 1, at nominal operating conditions

Section 2 General information

2.1 Safety information

Please read this entire manual before unpacking, setting up, or operating this equipment. Pay attention to all danger and caution statements. Failure to do so could result in serious injury to the operator or damage to the equipment.

To ensure that the protection provided by this equipment is not impaired, do not use or install this equipment in any manner other than that specified in this manual.

2.1.1 Use of hazard information

DANGER

Indicates a potentially or imminently hazardous situation which, if not avoided, could result in death or serious injury.

CAUTION

Indicates a potentially hazardous situation that may result in minor or moderate injury.

Important Note: Information that requires special emphasis.

Note: Information that supplements points in the main text.









2.1.2 Precautionary labels

Read all labels and tags attached to the instrument. Personal injury or damage to the instrument could occur if not observed. A symbol, if noted on the instrument, will be included with a danger or caution statement in the manual.



This symbol, if noted on the instrument, references the instruction manual for operation and/or safety information.

General information

	<p>Electrical equipment marked with this symbol may not be disposed of in European public disposal systems after 12 August of 2005. In conformity with European local and national regulations (EU Directive 2002/96/EC), European electrical equipment users must now return old or end-of life equipment to the Producer for disposal at no charge to the user.</p> <p>Note: For return for recycling, please contact the equipment producer or supplier for instructions on how to return end-of-life equipment, producer-supplied electrical accessories, and all auxiliary items for proper disposal.</p>
	<p>This symbol, when noted on a product enclosure or barrier, indicates that a risk of electrical shock and/or electrocution exists.</p>
	<p>This symbol, when noted on the product, identifies the location of the connection for Protective Earth (ground).</p>
	<p>This symbol, when noted on the product, identifies the location of a fuse or current limiting device.</p>
	<p>This symbol, when noted on the product, identifies a risk of chemical harm and indicates that only individuals qualified and trained to work with chemicals should handle chemicals or perform maintenance on chemical delivery systems associated with the equipment.</p>
	<p>This symbol, when noted on the product, identifies the presence of a strong corrosive or other hazardous substance and a risk of chemical harm. Only individuals qualified and trained to work with chemicals should handle chemicals or perform maintenance on chemical delivery systems associated with the equipment.</p>
	<p>This symbol, when noted on the product, indicated the presence of devices sensitive to Electro-static Discharge (ESD) and indicated that care must be taken to prevent damage with the equipment.</p>
	<p>This symbol, when noted on the product, identifies the presence of noxious substances and a risk of chemical harm. Only individuals qualified and trained to work with chemicals should handle chemicals or perform maintenance on chemical delivery systems associated with the equipment.</p>

2.2 General product information

DANGER

Explosion hazard. *The Hach GLI 3700 series sensors can only be used with the si792(x) E transmitter.*

2.2.1 Product overview

The si792 T, si792x T, si792 E and si792x E transmitters are used for measurement of electrical conductivity and temperature in liquids. Fields of application are: biotechnology, chemical industry, environment, food processing and water/waste-water treatment.

The E and the T models differ only in the types of sensors that can be used with the transmitter. The operation of each version is identical. This user manual refers to both versions as E/T.

The molded transmitter enclosure can be attached to a panel, wall, post or pipe railing. The optional hood (see [Accessories on page 81](#)) provides protection against direct weather exposure and mechanical damage.

Three communication options are available for the si792 transmitter:

- 4–20 mA/HART—si792 E, si792 T, si792x E and si792x T (noted as si792(x) E/T)
- Foundation Fieldbus—si792x E-FF* and si792x T-FF*
- Profibus PA—si792x E-PA* and si792x T-PA*

This user manual includes instructions for all three protocols.

Important Note: *An 'x' in the model number is an indication of an intrinsically safe (IS) instrument.*

The instruments are compatible with different sensor types. See [si792 transmitter versions on page 81](#) for a list of instrument versions.

* No longer available.

General information

2.2.2 FDA 21 CFR part 11 compliance (HART only)

In the directive “Title 21 Code of Federal Regulations, 21 CFR Part 11, Electronic Records; Electronic Signatures” the US American health agency FDA (Food and Drug Administration) regulates the production and processing of electronic documents for pharmaceutical development and production. The features described in [section 2.2.2.1](#) and [section 2.2.2.2](#) make the transmitter compliant with the requirements of FDA 21 CFR Part 11.

2.2.2.1 Electronic signatures for si792(x) E/T transmitters

Device functions are protected by passcode access, which prevents unauthorized modification of device settings or manipulation of measurement results. Passcodes may be used as electronic signatures. Passcodes can be edited with the passcode editor ([Appendix C on page 95](#)).

2.2.2.2 Audit trail for si792(x) E/T transmitters

The si792(x) transmitter can automatically track all changes to the device settings. Each change is tagged with a Configuration Change flag, which is documented using HART communication. Altered device settings or parameters can be retrieved from the transmitter using HART communication.

Section 3 Installation

DANGER

Explosion hazard. Trained personnel only must install or commission the equipment.

DANGER

Explosion hazard. Do not connect or disconnect any equipment unless power has been switched off or the area is known to be non-hazardous.

DANGER

Explosion hazard. The safety of the transmitter may be impaired if any of the following conditions have occurred:

- **visible damage**
- **storage above 70 °C for prolonged periods**
- **exposure to severe transport stresses**
- **previous installation**
- **failure to operate properly**

If any of these conditions have occurred, return the device to the manufacturer for recertification.

For outdoor installation, install a protective hood or sunshield (see [Accessories on page 81](#)).

3.1 Hazardous location installation

Before installation, review the applicable ATEX EC-Type Examination certificate and safety information included with the instrument. Follow all regulations specified for the installation location.

3.1.1 ATEX safety information

Refer to [Appendix D](#) for safety information on the use of the electrodeless sensors.

Installation

3.2 Unpacking the transmitter

Check the shipment for transport damage and make sure all components have been shipped complete. The package includes:

- Display module
- Bag of hardware and fasteners
- Back enclosure
- Test report and user manual

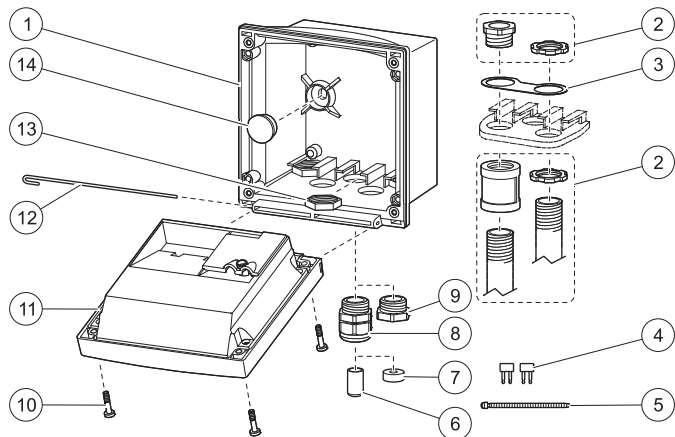

Figure 1 Instrument Components

1 Back enclosure	8 Strain relief (3x)
2 Optional conduit hardware	9 Filler plug (3x)
3 Conduit washer	10 Enclosure screw (4x)
4 Jumper (2x)	11 Display module
5 Cable tie (3x)	12 Hinge pin
6 Sealing insert	13 Hex nuts (5x)
7 Rubber reducer	14 Sealing plug (2x)

3.3 Mechanical installation

3.3.1 Transmitter assembly

Refer to [Figure 1](#) and the following instructions to assemble the transmitter.

1. Insert the strain relief fittings in the holes of the back enclosure and secure with the hex nuts ([Figure 2](#)).
2. Insert the conduit hardware or plugs in the back enclosure and secure with the hex nuts.
3. Attach the display module to the back enclosure using the hinge pin.

3.3.2 Mounting

Refer to the following sections to mount the transmitter on a wall, panel or pipe.

3.3.2.1 Wall mount

1. Use a punch to open the two wall-mount holes in the back enclosure ([Figure 2](#)).
2. Drill holes in the wall suitable for the user-supplied mounting bolts.
3. Attach the back enclosure to the wall using two customer-supplied bolts.
4. Insert the clear plastic plugs into the mounting holes.

3.3.2.2 Panel or pipe mount (optional)

Refer to [Figure 2](#) and the instructions supplied with the panel and pipe mounting kits (see [Accessories on page 81](#)).

Installation

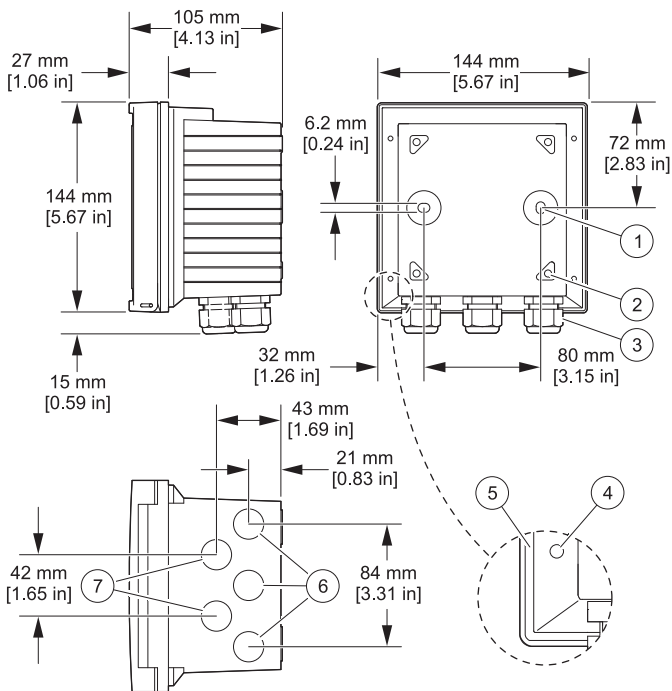

Figure 2 Wall attachment dimensions

1 Breakout for wall mounting (2x)	5 Groove for panel mount gasket
2 Hole for pipe mounting (4x)	6 Strain relief opening (3x)
3 Strain relief (3x)	7 Strain relief or ½ inch conduit opening
4 Breakout for panel mounting	(2x) Ø 21.5 mm [0.85 in]

3.4 Wiring Safety Information

When making any wiring connections to the instrument, the following warnings and notes must be adhered to, as well as any warnings and notes found throughout the individual installation sections. For more safety information refer to [section 2.1 on page 9](#).

DANGER

Always disconnect power to the instrument when making any electrical connections.

Electrostatic Discharge (ESD) Considerations

To minimize hazards and ESD risks, maintenance procedures not requiring power to the analyzer should be performed with power removed.

Delicate internal electronic components can be damaged by static electricity, resulting in degraded instrument performance or eventual failure.

The manufacturer recommends taking the following steps to prevent ESD damage to the instrument:

- Before touching any electronic components (such as printed circuit cards and the components on them) discharge static electricity from the body by touching an earth-grounded metal surface such as the chassis of an instrument or a metal conduit or pipe.
- To reduce static build-up, avoid excessive movement. Transport static-sensitive components in anti-static containers or packaging.
 - To discharge static electricity from the body and keep it discharged, wear a wrist strap connected by a wire to earth ground.
 - Handle all static-sensitive components in a static-safe area. If possible, use anti-static floor pads and work bench pads.

Installation

3.5 Electrical installation

DANGER

Explosion hazard. Do not connect any components that are not specified for the device.

Prerequisites:

- Review the applicable ATEX EC-Type Examination certificate
- Review the electrical code regulations
- Review the regulations for electrical installations in hazardous locations, if appropriate (e.g. EN 60079-10/EN60079-14; 94/9/EC directive; NEC; CEC; Profibus Technical Guidelines 2.091)
- Remove power or confirm non-hazardous status before making any connections
- Confirm that the intrinsic safety of the device is maintained when connected to other equipment such as a power supply unit.

3.5.1 Wire preparation

To remove the terminal blocks from the transmitter for sensor wiring:

1. Insert a flat screwdriver between the terminal block and the transmitter body.
2. Use the screwdriver as a lever to lift the terminal block off the connectors (see **Figure 3**).

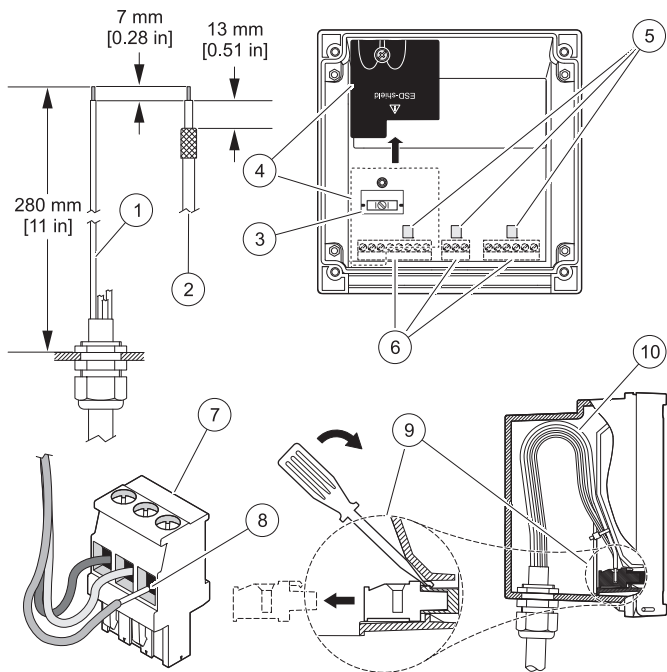

Figure 3 Wire preparation and insertion

1 Stripping lengths for cables	6 Terminals (vary by model number)
2 Stripping lengths for coaxial cables	7 Typical terminal
3 Cable shield connector (not used)	8 Seat insulation against connector
4 ESD shield removed	9 Removing terminal with screwdriver
5 Areas for screwdriver to pry terminal	10 Cable loop position in housing

Installation

3.5.2 Power and communication connections

DANGER

Explosion hazard. The AC power source for the power supply unit cannot exceed 250 VAC. Do not connect the transmitter directly to an AC power source.

DANGER

Explosion hazard. The output voltage of the power supply unit cannot exceed 30 VDC. The si792x transmitter must be connected to an appropriately certified explosion-proof power supply unit. Refer to "associated apparatus" to the EC-Type Examination Certificate for input ratings.

Prerequisites

- Trained personnel only must install or commission the equipment.
- Follow the instructions in this user manual and the applicable local and national codes.
- Observe the technical specifications and input ratings during installation.
- Disconnect all power sources during wiring and installation.
- Use single wires/flexible leads up to 2.5 mm (AWG 14) for connection to terminals.
- Do not damage the wire when stripping the insulation.
- All parameters must be set by a system administrator (Authority Having Jurisdiction) before commissioning.

3.5.2.1 si792(x) E/T (4-20 mA/HART) wiring

Refer to **Figure 4** and **Table 1** to connect the power supply to the si792(x) E/T transmitter.

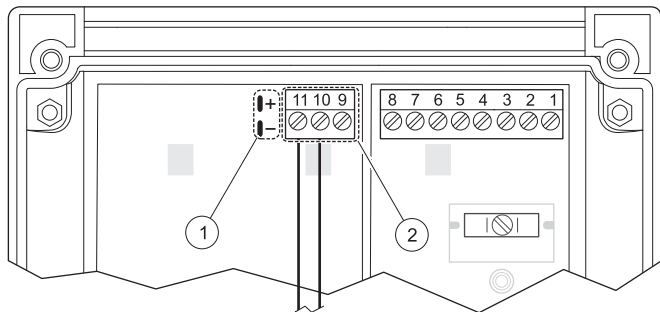

Figure 4 si792(x) E/T (4–20 mA/HART) wiring

1 HART connection (see warnings in section 3.6 on page 26)	2 Wiring terminals—see Table 1
--	---

Table 1 Terminal assignments—si792(x) E/T (4–20 mA/HART)

Terminal No.	Assignment
9	Potential equalization—ATEX only
10	4–20 mA output (+)
11	4–20 mA output (-)

Installation

3.5.2.2 si792x E/T-FF and si792x E/T-PA wiring

Refer to [Figure 5](#) and [Table 2](#) to connect power and communications to the si792x E/T-FF or si792x E/T-PA transmitters.

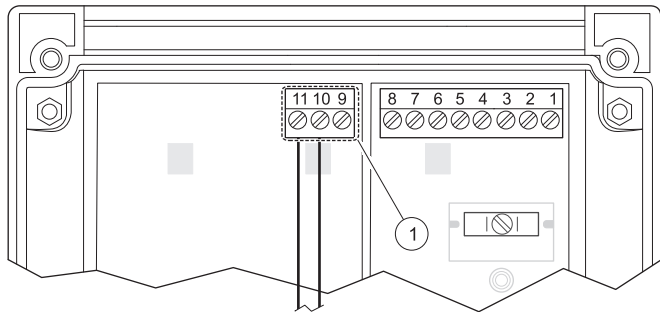

Figure 5 si792x E/T-FF and si792x E/T-PA wiring

1 Wiring terminals—see [Table 2](#)

Table 2 Terminal assignments—si792x E/T-FF and si792x E/T-PA

Terminal No.	Assignment
9	Potential equalization—ATEX only
10	Connection from Foundation Fieldbus or Profibus PA (-)
11	Connection from Foundation Fieldbus or Profibus PA (+)

3.5.3 Sensor wire connections

Important Note: Do not connect earth ground to the shield connector in the transmitter. Connect the cable shields to the shield connector.

Refer to the following sections to connect the transmitter to a sensor:

- Hach GLI 3700 series—[section 3.5.3.1 on page 23](#)
- 7MA2200 series—[section 3.5.3.2 on page 24](#)

- 8398 series—[section 3.5.3.3 on page 25](#)

3.5.3.1 Hach GLI 3700 series sensor wiring—si792(x) E

- Install the jumper between terminal 2 and 3 as shown in [Figure 6](#).
- Use [Table 3](#) to wire the sensor to the transmitter.

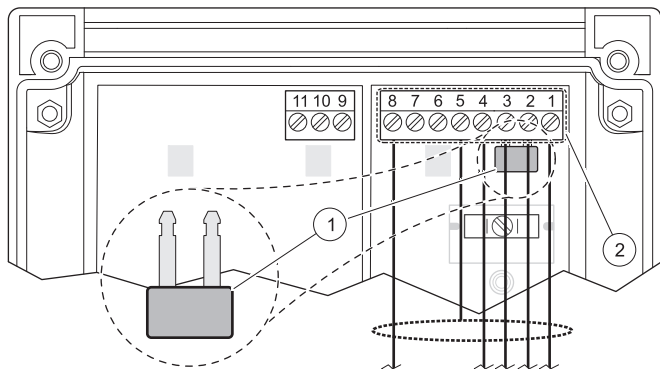

Figure 6 si792(x) E wiring for Hach GLI 3700 series sensors

1 Jumper between terminal 2 and 3

2 Wiring terminals—see [Table 3](#)

Table 3 Terminal assignments—Hach GLI 3700 series sensors

Terminal No.	Assignment	Wire color
1	Receive hi	white
2	Receive lo	blue
3	Send lo	yellow
4	Send hi	green
5	Cable shield connection <i>Note: Do not connect to earth ground.</i>	shield
8	RTD (resistive temperature device)	red

Installation

3.5.3.2 7MA2200 series sensor wiring—si792(x) T

1. Install the jumper between terminal 2 and 3 as shown in **Figure 7**.
2. Use **Table 4** to wire the sensor to the transmitter.

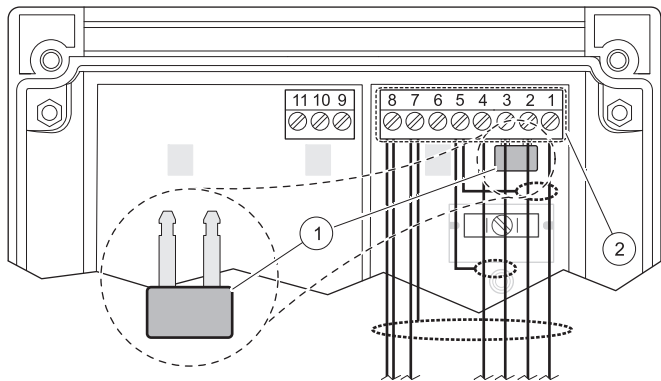

Figure 7 si792(x) T wiring for 7MA2200 series sensors

1 Jumper between terminal 2 and 3

2 Wiring terminals—see **Table 4**

Table 4 Terminal assignments—7MA2200 series sensors

Terminal No.	Assignment	Wire color
1	Receive hi	green
2	Receive lo	yellow
3	Send lo	white
4	Send hi	brown
5	Cable shield connection Note: Do not connect to earth ground.	violet/black
7	RTD (resistive temperature device)	blue/grey
8	RTD (resistive temperature device)	red/pink

3.5.3.3 8398 series sensor wiring—si792(x) T

1. Install the jumper between terminal 2 and 3 as shown in **Figure 8**.
2. Use **Table 5** to wire the sensor to the transmitter.

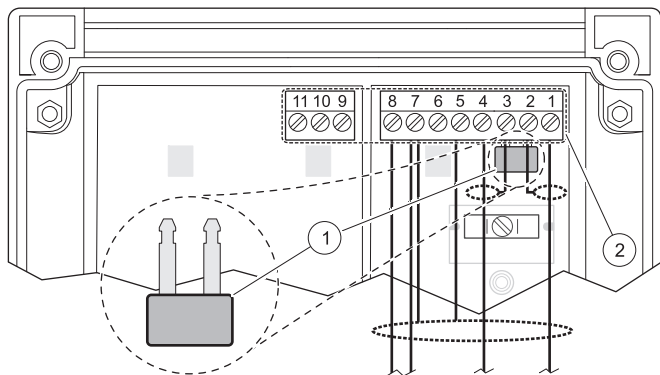

Figure 8 si792(x) T wiring for 8398 series sensors

1 Jumper between terminal 2 and 3	2 Wiring terminals—see Table 5
-----------------------------------	---------------------------------------

Table 5 Terminal assignments—8398 series sensor

Terminal No.	Assignment	Wire color
1	Receive hi	brown
2	Receive lo	black
3	Send lo	shield of brown wire
4	Send hi	shield of white wire
5	Cable shield connection Note: Do not connect to earth ground.	white
7	RTD (resistive temperature device)	green
8	RTD (resistive temperature device)	yellow

Installation

3.6 HART communication connection

DANGER

Explosion hazard. Do not connect or disconnect any equipment unless power has been switched off or the area is known to be non-hazardous.

DANGER

The si792x transmitter must be used with an explosion-proof HART communication device.

Refer to [Figure 4 on page 21](#) for the connector location.

Section 4 Interface and navigation

The si792 transmitter user interface contains a display, indicators and keys for navigation and menu selection.

4.1 si792(x) E/T (4–20 mA/HART) interface

Use the arrow and enter keys to scroll through the menu and change settings. Use the indicators to identify which mode the transmitter is in. Refer to **Figure 9** to identify the keys and indicators of the si792(x) E/T transmitter.

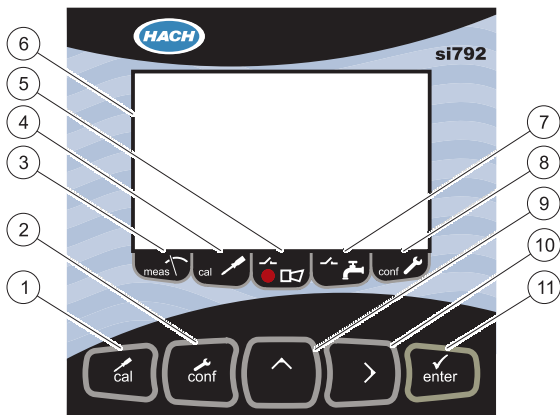

Figure 9 User interface—si792(x) E/T transmitter

1 Calibration key	7 Wash mode indicator (not available)
2 Configure key	8 Configuration mode indicator
3 Measure mode indicator	9 Up arrow key
4 Calibration mode indicator	10 Right arrow key
5 Alarm indicator	11 Enter key
6 Display	

Interface and navigation

4.2 si792x E/T-FF and si792x E/T-PA interface

Refer to **Figure 10** to identify the keys and indicators of the si792x E/T-FF and si792x E/T-PA transmitter.

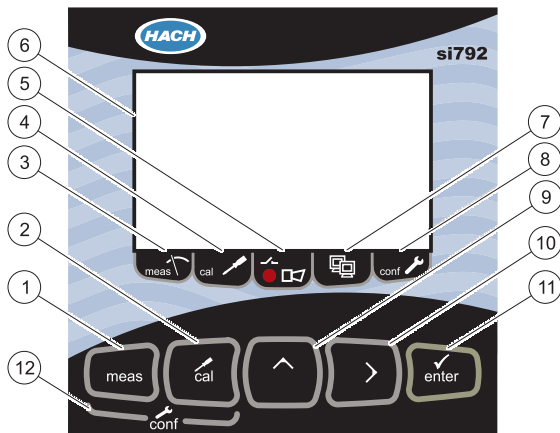

Figure 10 User interface—si792x E/T-FF and si792x E/T-PA

1 Measure key	7 Communication indicator
2 Calibration key	8 Configuration mode indicator
3 Measure mode indicator	9 Up arrow key
4 Calibration mode indicator	10 Right arrow key
5 Alarm indicator	11 Enter key
6 Display	12 Configuration mode

4.3 Display

Figure 11 identifies all of the possible icons and symbols that may be seen in the si792 transmitter display.

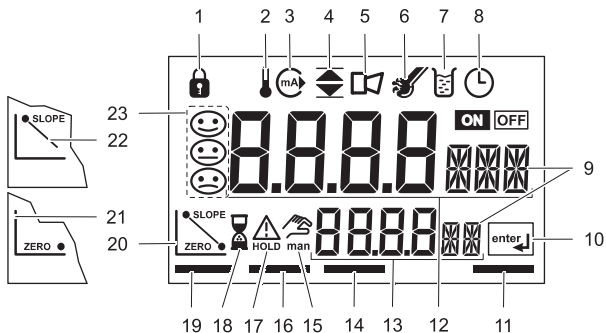

Figure 11 Display

1 Passcode	13 Secondary display
2 Temperature	14 Alarm mode
3 4–20 mA output	15 Manual temperature on
4 Limit values (FF and Profibus PA)	16 Calibration mode
5 Alarm	17 Hold mode active
6 Sensocheck—probe error	18 Hourglass (waiting indication)
7 Calibration active	19 Measure mode active
8 Calibration interval	20 Calibration complete
9 Parameter display	21 Calibration—zero or first point
10 Enter prompt	22 Calibration—second point
11 Configuration mode	23 Sensofaces
12 Main display	

Interface and navigation

Section 5 Operation—4–20 mA/HART

The following section describes how to operate the si792(x) E/T transmitter.

5.1 Measure mode

The display shows the configured process variable (conductivity, concentration, resistivity or salinity) and the temperature value in the measuring mode.

- To return to the measurement mode during calibration press **CAL** and **ENTER**.
- To return to the measurement mode during configuration press **CONF** and **ENTER**.

Note: The waiting time for the stabilization of the measured-value is approximately 20 seconds.

5.2 Configuration

Use the configuration mode to specify the sensor, range and other parameters for the system as shown in [Table 6](#).

1. Press **CONF** and enter **1200** to enter the configuration mode.
2. Use the arrow and enter keys to change the settings. All settings and options are shown in [section 5.2.1](#), [section 5.2.2](#) and [section 5.2.3](#).

Table 6 Configuration menu

Code	Parameter	Passcode
o1	4–20 mA current output	1200
tc	Temperature compensation	
AL.	Alarm settings	

To exit the configuration mode at any time, press **CONF** and **ENTER**. The output current will be held for 20 seconds and the measured value will be displayed.

Operation—4—20 mA/HART

Note: During configuration the transmitter remains in the Hold mode for safety reasons. The loop current is frozen at the value specified in the o1.HoLD menu option. The Sensoface icon is inactive. The configuration mode indicator is displayed ([Figure 11 on page 29](#)).

5.2.1 Current output configuration

Select the sensor		
o1.SnSR	si792 T:	2208 SIE (7MA2200 series; default)
		8398 PM
		Other
	si792 E:	3700 GLI (default)
		Other
Enter the cell factor ¹		
o1.CELL	0.100–20.000 (3.00 default—si792 T; 4.70 default—si792 E)	
Enter the transfer ratio ¹		
o1.SFC	1.00–200.00 (68.0 default—si792 T; 25.0 default—si792 E)	
Select the temperature sensor ¹		
o1.rTD	Pt100 (default—si792 T)	
	Pt1000 (default—si792 E for GLI/Hach 3700 series sensors)	
	NTC100	
	NTC30	
Select the range and units		
o1. UnIT	0.000 mS/cm (si792 T)	Conductivity range and resolution
	00.00 mS/cm	
	000.0 mS/cm (default)	
	0000 mS/cm	
	0.000 S/m	
	00.00 S/m	
	000.0 SAL	
	000.0%	Concentration (Conc)

Operation—4–20 mA/HART

5.2.1 Current output configuration (continued)

If range is set to 000.0% select solution (Conc)		
o1.ConC	-01- NaCl (default)	Solution (Conc) (refer to section B.1 on page 87 for more information)
	-02- HCl	
	-03- NaOH	
	-04- H ₂ SO ₄	
	-05- HNO ₃	
	-06- H ₂ SO ₄	
	-07- HCl	
	-08- HNO ₃	
	-09- H ₂ SO ₄	
	-10- NaOH	
Select characteristic (Linear / Logarithmic curve)		
o1.CHAR ²	LIN (default)	Linear/Logarithmic curve
	LOG	
Specify the value for the 4 and 20 mA signals		
o1.4mA	000.0 mS	LIN: Enter current start
o1.20mA	000.0 mS	LIN: Enter current end
o1.4mA	1 mS (default)	LOG: Enter current start
o1.20mA	100 mS (default)	LOG: Enter current end
Set time averaging filter for reducing noise		
o1.FtME	0 SEC (default)	Time constant of output filter (refer to section 5.2.1.1 for more information)
Select a 22 mA signal during errors		
o1.FAIL	ON	
	OFF (default)	
Signal behavior during HOLD		
o1.HOLD	LAST (default)	During HOLD the last measured value is maintained at the output
	FIX	During HOLD a value (to be entered) is maintained at the output

Operation—4—20 mA/HART

5.2.1 Current output configuration (continued)

Specify the value to output during HOLD periods		
o1.FIX	21.0 mA (default)	During HOLD the entered value is maintained at the output (refer to section 5.2.1.3 for more information)

¹If “Other” sensor is selected, o1.CELL, o1.SFC and o1.rTD are available

²If the process variables SAL, % (Conc) or USP are selected the following steps (Lin/Log) are omitted.

Note: During configuration the instrument/transmitter remains on **Hold**. Depending on the configuration the loop current is frozen at its last value or at a preset fixed value.

Press **ENTER** to access a menu item. Use the **ARROW KEYS** to edit values. Press **ENTER** to save the settings. If a value is outside of the acceptable range, “Err” will be displayed and the value will not be accepted. To exit the menu and return to the measurement mode, press **CONF** and **ENTER**.

Example: Set the output start point for the 4 mA signal to be 10.0 mS and the output end point to be 100 mS for the 1.20 mA signal.

1. Press **CONF**, enter passcode: **1200**. The display will show Conf and then **out.1MNU**.
2. Press **ENTER** to access the output setup menu. The display will show **CELL**.
3. Press **ENTER**, **ENTER**, **ENTER** to reach the 4 mA submenu. The display will show **o1.4mA**.
4. Use the **UP ARROW** and **RIGHT ARROW** to edit the value to read 10.0 mS value. Press **ENTER** to save the value. The display will show **o1.20mA**.
5. Use the **UP ARROW** and **RIGHT ARROW** to edit the value to read 100.0 mS value. Press **ENTER** to save the value. The display will show **o1.FtME**.

Operation—4–20 mA/HART

6. Press **CONF** and **ENTER** to exit the configuration menu.

The transmitter remains in HoLD mode for approximately 20 seconds after calibration and returns to the measurement mode.

5.2.1.1 Time constant of output filter

An averaging filter is available to reduce noise in the output signal. The filter averages readings over a specified time interval. The time interval can be set from 0 to 120 seconds (default: 0 seconds).

When set to 0 seconds, there is no signal averaging for noise reduction. When set to 120 seconds, the current output value will be correspond to the process signal averaged over the last 120 seconds. Increase the time interval to reduce the noise in the output signal.

Note: *The filter acts on the output signal but not on the displayed value.*

5.2.1.2 Output signal during errors

When an error condition occurs, a 22 mA output signal can be sent as a notification (default: off).

Operation—4–20 mA/HART

5.2.1.3 Output signal during HOLD

The output signal during hold periods can be maintained at the last measured value (Figure 12) or fixed at a specified value (Figure 13). The allowable range for the fixed value is 3.4 to 22 mA.

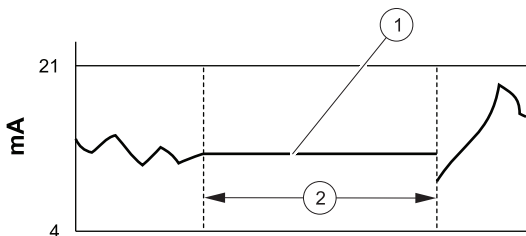

Figure 12 Output signal during HOLD—last value

1 Output signal during HOLD	2 HOLD mode
-----------------------------	-------------

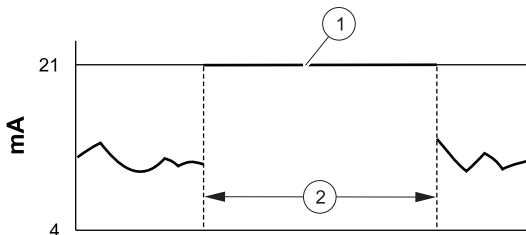

Figure 13 Output signal during HOLD—fixed value

1 Output signal during HOLD	2 HOLD mode
-----------------------------	-------------

Operation—4—20 mA/HART

5.2.2 Temperature compensation configuration

Select temperature unit		
tc.UniT	°C (default)	
	°F	
Select temperature compensation ¹		
tc. LIN	Lin (default)	Linear temperature compensation with entry of temperature coefficient. Reference temperature = 25 °C
		Enter temperature coefficient 02.00%/K (default) (xx.xx%/K)
	nLF	Temperature compensation for natural waters to EN 27888
	OFF	Temperature compensation turned off

¹If SAL or USP is selected, the following steps are omitted.

Note: Calibrate a temperature sensor adjustment for a correct temperature measurement. Use a separate temperature sensor with fast response for measuring processes with rapid temperature changes.

Press **ENTER** to access a menu item. Use the **ARROW KEYS** to edit values. Press **ENTER** to save the settings. If a value is outside of the acceptable range, "Err" will be displayed and the value will not be accepted. To exit the menu and return to the measurement mode, press **CONF** and **ENTER**.

Operation—4—20 mA/HART

5.2.3 Alarm settings

Select Sensocheck		
AL.SnSO	CHECK ON	Continuous Sensocheck evaluation of sensor function
	CHECK OFF (default)	
Enter alarm delay		
AL.dLY	0010 sec (default)	Range: 0–600 sec
LED in Hold mode		
AL.LED	HOLD ON	LED blinks during hold
	HOLD OFF	LED off during hold

Section 6 Operation—Foundation Fieldbus

The following section describes how to navigate and operate the si792x E/T-FF transmitter. The transmitter can be operated as follows:

- Direct interface with the transmitter ([section 6.1](#))
- Foundation Fieldbus communication ([section 6.2 on page 43](#))

6.1 Configuration

Use the configuration mode to specify the sensor, range and other parameters for the system.

6.1.1 Configuration steps

Complete the following steps to configure the si792 transmitter.

1. Press **MEAS + CAL** and then enter **1200** to enter the configuration mode.
2. Use the arrow and enter keys to change the settings. All settings and options are shown in [section 6.1.2](#).

To exit the configuration mode at any time, press **MEAS + CAL** and then **ENTER**. The Hold mode will be active for 20 seconds and then the measured value will be displayed.

Note: During configuration the transmitter remains in the Hold mode for safety reasons. The Sensoface icon is inactive. The configuration mode indicator is displayed ([Figure 11 on page 29](#)).

Operation—Foundation Fieldbus

6.1.2 Configuration menu

Select the sensor		
In.SnSR	si792 T:	2208 SIE (7MA2200 series; default)
		8398 PM
		Other
	si792 E:	3700 GLI (default)
		Other
Select nominal cell factor (other sensor)		
In.CELL	00.100 – 20.000 (default: 1.980)	
Select the transfer ratio (other sensor)		
In.SFC	0010.00 – 2000.00 (default: 120.00)	
Select temperature probe (other sensor)		
In.rTD	100 PT (default)	
	1000 PT	
	100 NTC	
	30 NTC	

Operation—Foundation Fieldbus

6.1.2 Configuration menu (continued)

Select the variable/unit				
In.UnIT	0.000 mS/cm			
	00.00 mS/cm			
	000.0 mS/cm (default)			
	0.000 S/m			
	00.00 S/m			
	00.00 SAL			
	000.0%	In.CoNC	-01- NaCl (default)	
			-02- HCl	
			-03- NaOH	
			-04- H ₂ SO ₄	
-05- HNO ₃				
-06- H ₂ SO ₄				
-07- HCl				
-08- HNO ₃				
-09- H ₂ SO ₄				
-10- NaOH				
Select temperature unit				
tc.UnIT	°C (default)			
	°F			
Select temperature compensation				
tc.	OFF	Temperature compensation turned off		
	LIN (default)	Linear temperature compensation Enter temperature coefficient: Range: 0–19.99%/K (default: 2.00%/K) Reference temperature = 25 °C		
	nLF	Natural waters (to EN 27888)		
Select Sensocheck				
AL.SnSO	CHECK ON	Continuous Sensocheck evaluation of sensor function		
	CHECK OFF (default)			

Operation—Foundation Fieldbus

6.1.2 Configuration menu (continued)

LED in Hold mode		
AL.LED	HOLD ON	LED blinks during hold
	HOLD OFF (default)	LED off during hold
Enter Fieldbus address (optional) ¹		
FF.ADR	0017 – 0031 BUS (default: 0026 BUS)	

¹Use only when there is no bus connection. The transmitter will restart and set all parameters to default values. Individual settings must be entered once more.

6.2 Foundation Fieldbus communication

Use the Foundation Fieldbus specification to set up and configure the si792 transmitter. The communication parameters are listed in the following sections. The sensor can be calibrated as described in [section 6.2.4 on page 59](#).

6.2.1 Standard resource block (RB)

The standard resource block describes the transmitter characteristics (manufacturer, device name, operating status, global status). The resource block must be in automatic mode for any of the other blocks to operate. The bus parameters for the standard resource block (RB) are shown in [Table 7](#).

Table 7 Bus parameters—resource block (RB)

Parameter	Description	Default	R/W
ST_REV	Static revision	0	R
TAG_DESC	TAG description		R/W
STRATEGY	Strategy	0	R/W
ALERT_KEY	Alert key	0	R/W
MODE_BLK	Target	OOS	R/W
	Actual		
	Permitted	OOS, Auto	
	Normal	Auto	
BLOCK_ERR	Block error		R
RS_STATE	Resource state	1	R
TEST_RW	Test		R/W
DD_RESOURCE	DD resource		R
MANUFAC_ID	Manufacturer ID	0x001D6D for Hach	R
DEV_TYPE	Device type	si792 T: 0068 si792 E: 0066	R
DEV_REV	Device revision	1	R
DD_REV	DD revision	1	R

Operation—Foundation Fieldbus

Table 7 Bus parameters—resource block (RB) (continued)

Parameter	Description	Default	R/W
GRANT_DENY	Grant	0	R/W
	Deny	0	R/W
HARD_TYPES	Hardware type	1	R
RESTART	Restart		R/W
FEATURES	Feature supported	Reports/ Soft W Lock	R
FEATURES	Feature selected	Reports/ Soft W Lock	R/W
CYCLE_TYPE	Cycle type	Scheduled/ Block Execution	R
CYCLES_SEL	Cycle selected	Scheduled/ Block Execution	R/W
MIN_CYCLE_T	Min cycle time	1600 ¹ / ₃₂ ms (50 ms)	R
MEMORY_SIZE	Memory size		R
NV_CYCLE_T	Non-volatile cycle time		R
FREE_SPACE	Free space		R
FREE_TIME	Free time		R
SHED_RCAS			R/W
SHED_ROUT			R/W
FAULT_STATE	Fault state		R
SET_FSTATE	Set fault state	1	R/W
CLR_FSTATE	Clear fault state	1	R/W
MAX_NOTIFY	Max notifications	20	R
LIM_NOTIFY	Limit of notification	8	R/W
CONFIRM_TIME	Confirmation time	640000 ¹ / ₃₂ ms	R/W
WRITE_LOCK	Write locking	1 (unlocked)	R/W
UPDATE_EVT	Unacknowledged	0	R/W
	Update state	0	R
	Time stamp	0	R
	Static revision	0	R
	Relative index	0	R/W

Operation—Foundation Fieldbus

Table 7 Bus parameters—resource block (RB) (continued)

Parameter	Description	Default	R/W
BLOCK_ALM	Unacknowledged		R/W
	Alarm state		R
	Time stamp		R
	Sub-code		R
	Value		R
ALARM_SUM	Current		R
	Unacknowledged		R
	Unreported		R
	Disabled		R/W
ACK_OPTION	Automatic acknowledge option	0 (disabled)	R/W
WRITE_PRI	Write priority	0	R/W
WRITE_ALM	Unacknowledged		R/W
	Alarm state		R
	Time stamp		R
	Sub-code		R
	Value		R
ITK_VER	ITK_version	4	R
DEVICE_LOCK	Locks the device for local access. 1 byte Data type = uns8 Range: 0 (unlocked) 1 (locked)	0 (unlocked)	R/W

Operation—Foundation Fieldbus

6.2.2 Standard analog input block (AI)

Three Analog Input Function Blocks provide for cyclic transmission of measured values (currently measured value with status, alarm limits, freely selectable process parameter).

6.2.2.1 Operating modes

Use the MODE_BLK parameter to set the following operating modes:

- OOS—out of service. If not write-protected, access to all parameters is allowed.
- MAN—manual
- Auto—online, normal state

6.2.2.2 Set the parameter and units

Use CHANNEL to set the measured parameter and units ([Table 8](#)). The corresponding measurement unit is selected in the UNITS subparameter of XD_SCALE ([Table 9 on page 48](#)).

Table 8 Measurement parameters and units

Channel	Parameter	Unit	Unit value
1	Conductivity	$\mu\text{S/cm}$	1586
		mS/cm	1302
		S/cm	1299
2	Concentration	% (percent)	1342
3	Temperature	$^{\circ}\text{C}$	1001
		$^{\circ}\text{F}$	1002
4	Salinity	‰ (parts per thousand)	2003
5	Resistance	M Ω /cm	1587
6	Cell constant	cm^{-1}	2004

Operation—Foundation Fieldbus

6.2.2.3 Data processing

Use the L_TYPE parameter to apply a linearization function to the data.

- **Direct**—data is sent directly from the TB to the AI without processing. The units for the XD_SCALE and OUT_SCALE parameters must be identical.
- **Indirect**—data from the TB is linearly scaled from the input scale (XD_SCALE) to the output scale (OUT_SCALE).
- **Indirect square root**—data is rescaled from the input scale (XD_SCALE) and recalculated using a root function. Then the value is linearly scaled to the output scale (OUT_SCALE).

6.2.2.4 Alarms

The AI block can generate block alarms and limit alarms. Use the ACK_OPTION parameter to specify if an alarm must be acknowledged. When the measured value status is “bad”, the AI block BLOCK_ERR parameter indicates an Input Failure.

- **Block alarms**—a block error will be reported via the BLOCK_ERR parameter (simulate active, input failure, block configuration error, out of service (OOS)). The BLOCK_ALM parameter sends the alarm status to the control system.
- **Limit alarms**—the measured value OUT falls outside of the limit values (HI_HI_LIM, HI_LIM, LO_LIM, LO_LO_LIM).

If an alarm occurs, evaluate the following bus parameters:

- OUT parameter (currently measured value) in the AI block
- LAST_ERROR parameter in the transducer block
- SENSOFACE_STATUS parameter in the transducer block

Operation—Foundation Fieldbus

6.2.2.5 Bus parameters for the analog input block

The bus parameters for the analog input function block (AI) are shown in [Table 9](#).

Table 9 Bus parameters/analog input blocks (AI)

Parameter	Description	Default	R/W
ST_REV	Static Revision	0	R
TAG_DESC	TAG Description		R/W
STRATEGY	Strategy	0	R/W
ALERT_KEY	Alert Key	0	R/W
MODE_BLK	Target	OOS	R/W
	Actual	—	
	Permitted	OOS, Auto	
	Normal	Auto	
BLOCK_ERR	Block Error		R
PV	Process Value		R
	Status		R
OUT	Measured Value		R
	Status		R
SIMULATE	Simulate Status		R/W
	Simulate Value		R/W
	Transducer Status		R
	Transducer Value		R
	Simulate Enable / Disable		R/W
XD_SCALE	High Range	100	R/W
	Low Range	0	R/W
	Units Index	0	R/W
	Decimal Point	0	R/W
OUT_SCALE	High Range	100	R/W
	Low Range	0	R/W
	Units Index	0	R/W
	Decimal Point	0	R/W

Operation—Foundation Fieldbus

Table 9 Bus parameters/analog input blocks (AI) (continued)

Parameter	Description	Default	R/W
GRANT_DENY	Grant	0	R/W
	Deny	0	R/W
IO_OPTS	IO Block Options	0	R/W
STATUS_OPTS	Status Options		
CHANNEL	Channel	1	R/W
L_TYPE	Linearization Type	0	R/W
LOW_CUT	Low Cut Off	0	R/W
PV_TIME	Filter Time	0	R/W
FIELD_VAL	Percent Value		R
	Status		R
UPDATE_EVT	Unacknowledged	0	R/W
	Update State	0	R
	Time Stamp	0	R
	Static Revision	0	R
	Relative Index	0	R
BLOCK_ALM	Unacknowledged	0	R/W
	Alarm State	0	R
	Time Stamp	0	R
	Sub-code	0	R
ALARM_SUM	Current	0	R
	Unacknowledged	0	R
	Unreported	0	R
	Disabled	0	R/W
ACK_OPTION	Automatic Acknowledge Option	0	R/W
AIARM_HYS	Alarm Hysteresis	0.50%	R/W
HI_HI_PRI	High High Priority	0	R/W
HI_HI_LIM	High High Limit	INF	R/W
HI_PRI	High Priority	0	R/W
HI_LIM	High Limit	INF	R/W
LO_PRI	Low Priority	0	R/W

Operation—Foundation Fieldbus

Table 9 Bus parameters/analog input blocks (AI) (continued)

Parameter	Description	Default	R/W
LO_LIM	Low Limit	-INF	R/W
LO_LO_PRI	Low Low Priority	0	R/W
LO_LO_LIM	Low Low Limit	-INF	R/W
HI_HI_ALM	Unacknowledged	0	R/W
	Alarm State	0	R
	Time Stamp	0	R
	Sub-code	0	R
	Value	0	R
HI_ALM	Unacknowledged	0	R/W
	Alarm State	0	R
	Time Stamp	0	R
	Sub-code	0	R
	Value	0	R
LO_ALM	Unacknowledged	0	R/W
	Alarm State	0	R
	Time Stamp	0	R
	Sub-code	0	R
	Value	0	R
LO_LO_ALM	Unacknowledged	0	R/W
	Alarm State	0	R
	Time Stamp	0	R
	Sub-code	0	R
	Value	0	R

Operation—Foundation Fieldbus

6.2.2.6 Cyclic measured value status

The cyclic measured value status is shown in [Table 10](#).

Table 10 Cyclic measured value status

Priority	Quality	Sub-status	Bin-coding (no limit bits)	Hex-coding
Low	Good	Good Non-Specific	10 00 00 00	0 x 80
		Good Active Advisory Alarm	10 00 10 xx	0 x 88
		Good Active Critical Alarm	10 00 11 xx	0 x 8C
	Uncertain	Uncertain Non-Specific	01 00 00 xx	0 x 40
		Last Usable Value (LUV)	01 00 01 xx	0 x 44
		Substitute-Set	01 00 10 xx	0 x 48
		Initial Value	01 00 11 xx	0 x 4C
		Sensor Conversion Not Accurate	01 01 00 xx	0 x 50
		Engineering Unit Violation	01 01 01 xx	0 x 54
		Sub-Normal	01 01 10 xx	0 x 58
	Bad	Non-Specific	00 00 00 xx	0 x 00
		Sensor Failure	00 01 00 xx	0 x 10
		Device Value	00 00 11 xx	0 x 0C
		Out of Service	00 01 11 xx	0 x 1C
	High			

6.2.2.7 Measured value limits—limit bits

The respective status bit is set when a condition occurs ([Table 11](#)). The status bit is reset when the condition no longer exists.

Table 11 Limit bit description

Bin coding of limit bits	Description
00	OK
01	Low-limited
10	High-limited
11	Constant

6.2.3 Transducer block

The transducer block provides for acyclic data transmission. Calibration, configuration, and maintenance commands coming from the control station are processed in the Transducer Block. The bus parameters for the transducer block (TB) are shown in **Table 12** (default values are in bold type).

Table 12 Transducer block parameters

Parameter	Description	R/W	Bytes	Data type	Range
ST_REV	The revision of the static data associated with the function block. Used by the host to determine when to re-read the static data.	R	2		The revision value is incremented every time a static parameter in the block is changed.
TAG-DESC	The user description of the intended application of the block.	R/W	32		Default: Text
STRATEGY	The strategy field can be used to identify a grouping of blocks. Can be used for any purpose by the user.	R/W	2		Default: 0
ALERT_KEY	Identification number that may be used by the host system to sort alarms and other device information.	R/W	1		Default: 0

Table 12 Transducer block parameters (continued)

Parameter	Description	R/W	Bytes	Data type	Range
MODE_BLK	Allows the user to set the Target, Permitted, and Normal device mode. Displays the Actual mode. Target Actual Permitted Normal	R/W R R/W R/W	1 1 1 1		Available modes: Automatic, Out Of Service (OOS), Manual
BLOCK_ERR	Reflects the error status associated with the hardware or software of the block. It is a bit string so multiple errors may be shown.	R	2		
UPDATE_EVENT	Unacknowledged Update State Time Stamp Static Rev Relative Index	R	1 1 8 2 2		Default: 0
BLOCK_ALM	Unacknowledged Alarm State Time Stamp Subcode Value	R	1 1 8 2 1		Default: 0

Operation—Foundation Fieldbus

Table 12 Transducer block parameters (continued)

Parameter	Description	R/W	Bytes	Data type	Range
TRANSDUCER_DIRECTORY	Directory that specifies the number and the starting indices of the transducers in the transducer block.	R	4		
TRANSDUCER_TYPE	Identifies the transducer type.	R	2		Default: 65535 = other
XD_ERROR	A transducer block sub-code. XD_ERROR contains the highest priority alarm that has been activated in the TB_DETAILED_STATUS parameter.	R	1		Default: 0
COLLECTION_DIRECTORY	A directory that specifies the number, starting indices, and DD item of IDs of the data collection in each transducer within a transducer block. Used by the host for efficient transfer of information.	R	36		
Output					
SENSOR_CONNECTION (sI792x T)	Selects the connection of the sensor	R/W	1	uns8	0 = 2208 SIE 1 = 8398 PM 2 = Other
SENSOR_CONNECTION (sI792x E)	Selects the connection of the sensor	R/W	1	uns8	0 = 3700 GLI 1 = Other

Table 12 Transducer block parameters (continued)

Parameter	Description	R/W	Bytes	Data type	Range
PRIMARY_VALUE	Shows the primary value and status Value Status	R	4 1	DS_65	
PRIMARY_VALUE_TYPE	Selects the displayed primary value	R/W	1	uns16	1 = 0.000 mS/cm 2 = 00.00 mS/cm 3 = 000.0 mS/cm 4 = 0.000 S/m 5 = 00.00 S/m 6 = SAL 7 = 000.0% (Conc)
CONCENTRATION	Selects the solution used for concentration measurement.	R/W	2	uns8	1 = -01- NaCl 2 = -02- HCl 3 = -03- NaOH 4 = -04- H ₂ SO ₄ 5 = -05- HNO ₃ 6 = -06- H ₂ SO ₄ 7 = -07- HCl 8 = -08- HNO ₃ 9 = -09- H ₂ SO ₄ 10 = -10- NaOH

Operation—Foundation Fieldbus

Table 12 Transducer block parameters (continued)

Parameter	Description	R/W	Bytes	Data type	Range
Temperature					
SECONDARY_VALUE_2	Process temperature value and status Value Status	R R	4 1	DS_65	
SECONDARY_VALUE_UNIT_2	Degree C or degree F. Changes the unit of temperature being displayed and transmitted.	R/W	2	uns16	1001 = °C 1002 = °F
TEMP_SENSOR_TYPE	Type of temperature sensor. The value entered must correspond to the temp. sensor being used.	R/W	2	uns16	128 = Pt100 200 = Pt1000 1000 = NTC30 1003 = NTC100
TEMP_COMPENSATION	Selects the temperature compensation	R/W	1	uns8	0 = TC OFF 1 = TC LIN 2 = TC nLF
TEMP_COEFFICIENT	Sets the temperature coefficient if the TEMP_COMPENSATION is set to Lin	R/W	4	float	00.00 to 19.99%/K Default: 2.00%/K
TEMP_WIRE_IMPEDANCE	Sets the wire impedance of the temp. sensor. Typically 0 unless the wire of the sensor gets too long	R/W	4	float	Default: 0 Ω

Table 12 Transducer block parameters (continued)

Parameter	Description	R/W	Bytes	Data type	Range
TEMP_SENSOR_CAL	Desired temperature reading, used for temperature measurement calibration.	R/W	4	float	-10 to +10K Default: 0
Calibration					
CELL_FACTOR	Sets the cell factor.	R/W	4	float	0 to 20.0 Default: 1.98
ZERO	Sets the zero value.	R/W	4	float	-0.5 to +0.5 mS Default: 1.0
TRANSFER_RATIO	Sets the transfer ratio.	R/W	4	float	1.0 to 200.0 Default: 120.0
CAL_SAMPLE_PRD	Starts the 1st part of conductivity product calibration.	R/W	1	uns8	0 = Nop 1 = Sample
CAL_SAMPLE_PRD_STORED_VAL	Shows the stored value of the first step of conductivity product calibration	R	4	float	Default: 0 if step 1 of product calibration was not started
CAL_PRODUCT	Sets the value for the 2nd part of conductivity product calibration.	R/W	4	float	Default: 0.0
Alert					
HOLD	Sets the device to HOLD mode.	R/W	1	uns16	0 = Off 1 = On
SENSOCHECK	Enables or disables Senso-check.	R/W	1	uns8	0 = Off 1 = On

Operation—Foundation Fieldbus

Table 12 Transducer block parameters (continued)

Parameter	Description	R/W	Bytes	Data type	Range
ALARM_LED_MODE	Sets the LED to HOLD mode.	R/W	1	uns8	0 = Off 1 = On
LAST_ERROR	Shows the last error.	R	2	uns16	0...100 Default: 0 = None
SENSOFACE_STATUS	Shows the current status of the Sensoface.	R	1	uns8	0 = Good 1 = Neutral 2 = Bad
Identification and local parameter setting					
SW_REV_LEVEL	Software revision number	R	2	uns16	
HW_REV_LEVEL	Hardware revision number	R	1	uns8	

Operation—Foundation Fieldbus

6.2.4 Calibration via Foundation Fieldbus

The transmitter can be calibrated via Foundation Fieldbus using the comparison or grab sample method.

1. Make sure the system is configured for conductivity (PRIMARY_VALUE_TYPE = mS/cm or S/m).
2. Collect a grab sample and set CAL_SAMPLE_PRD to sample. The conductivity value of the sample is stored. After writing, the parameter is automatically reset to NOP (no operation).
3. Read the parameter CAL_SAMPLE_PRD_STORED_VAL. It contains the stored value.
4. Measure the grab sample and write the lab value in CAL_PRODUCT. The device is now calibrated. CAL_SAMPLE_PRD_STORED_VAL is reset to zero.

Operation—Foundation Fieldbus

Section 7 Operation—Profibus PA

The following section describes how to navigate and operate the si792x Profibus-PA transmitter. The transmitter can be operated as follows:

- direct interface with the transmitter ([section 7.1](#))
- remote operation from the control station ([section 7.2 on page 63](#))

Note: Calibration must be completed by direct interface with the transmitter.

7.1 Configuration

Use the configuration mode to specify the sensor, range and other parameters for the system.

7.1.1 Configuration steps

Complete the following steps to configure the si792 transmitter.

1. Press **MEAS + CAL** and then enter **1200** to enter the configuration mode.
2. Use the arrow and enter keys to change the settings. All settings and options are shown in [section 7.1.2](#).

To exit the configuration mode at any time, press **MEAS + CAL** and then **ENTER**. The Hold mode will be active for 20 seconds and then the measured value will be displayed.

Note: During configuration the transmitter remains in the Hold mode for safety reasons. The Sensoface icon is inactive. The configuration mode indicator is displayed ([Figure 11 on page 29](#)).

Operation—Profibus PA

7.1.2 Configuration menu

Select the range and units			
	0.000 mS		
	00.00 mS		
	000.0 mS (default)		
	0000 mS		
	000.0%	-01- NaCl (default)	
		-02- HCl	
		-03- NaOH	
		-04- H ₂ SO ₄ (0 – 35% by weight)	
-05- HNO ₃			
-06- H ₂ SO ₄ (95 – 99% by weight)			
000.0 SAL			
Select temperature unit			
	°C (default)		
	°F		
Select temperature sensor			
	100 PT (default)		
	1000 PT		
	30 NTC		
	100 NTC		
	busEXT (external temp during measurement; manual temp during calibration, °C)		
Select temperature compensation ¹			
tc	OFF	Temperature compensation turned off	
	LIN (default)	Linear temperature compensation with entry of temperature coefficient (00.00–19.99%/K). Reference temperature = 25 °C.	
		Enter temperature coefficient 02.00%/K (default) (xx.xx%/K)	
nLF	Temperature compensation for natural waters to EN 27888		

7.1.2 Configuration menu (continued)

Select Sensocheck		
	CHECK ON	Continuous Sensocheck evaluation of sensor function
	CHECK OFF (default)	
Enter Profibus address ²		
Edit	0001–0126 BUS (default: 0126)	

¹Temperature compensation is not available for salinity.

²Use only when there is no bus connection. The transmitter will restart and set all parameters to default values. Individual settings must be entered once more.

7.2 Profibus PA communication

Profibus uses a master/slave data exchange technique. The master (typically a PLC) generates queries to individual slaves. The slaves, in turn, reply back with a response to the master. A Profibus message contains the information required to send a query or request, including the slave address, function code, data, and a checksum. See [Table 13 on page 64](#) for Profibus communication parameters in case of errors.

Operation—Profibus PA

Table 13 PROFIBUS communication

Cause	No. of binary message	Analog input status	Physical Block (PB) Global status	Text of binary message (default)	Logbook (default)
Factory settings defective	1	0000 11xx	Failure	ERR SYSTEM	Yes
Configuration data defective, Gaincheck	2	0000 11xx	Failure	ERR PARAMETERS	Yes
Memory error (RAM, ROM, EPROM)	3	0000 11xx	Failure	ERR MEMORY	Yes
Cond, sal range violation	4	0101 01xx	Failure	ERR MEAS VALUE	Yes
Conductance range violation	5	0100 0111 0100 1111	Failure	ERR COND VALUE	Yes
Temp range violation Temperature probe	6	0100 0111 0100 1111	Failure	ERR TEMP VALUE	Yes
Sensocheck	7	0100 0111 0100 1111	Failure	CHK SENSOR	Yes
Cell constant	8	1010 01xx	Maintenance req.	CHK SLOPE	Yes
Calibration	9	0100 0111 0100 1111	Function check	CAL RUNNING	Yes
Configuration	10	1010 00xx	Function check	CONF RUNNING	Yes

Table 13 PROFIBUS communication (continued)

Cause	No. of binary message	Analog input status	Physical Block (PB) Global status	Text of binary message (default)	Logbook (default)
HOLD (Device state = Maintenance)	11	0100 0111 0100 1111	Function check	HOLD	X
HI_HI_LIM FB analysis Cond/MO/SAL	12	1000 1110	Limit 1 Bit 1	HI_HI_LIMIT COND HI_HI_LIMIT MOcm HI_HI_LIMIT SAL	
HI_LIM FB analysis Cond/MO/SAL	13	1000 1010	Limit 1 Bit 2	HI_LIMIT COND HI_LIMIT MΩ cm HI_LIMIT SAL	
LO_LIM FB analysis Cond/MO/SAL	14	1000 1001	Limit 1 Bit 3	LO_LIMIT COND LO_LIMIT MΩ cm LO_LIMIT SAL	
LO_LO_LIM FB analysis Cond/MO/SAL	15	1000 1101	Limit 1 Bit 4	LO_LO_LIMIT COND LO_LO_LIMIT MOcm LO_LO_LIMIT SAL	
HI_HI_LIM FB temperature	16	1000 1110	Limit 2 Bit 1	HI_HI_LIMIT TEMP	
HI_LIM FB temperature	17	1000 1010	Limit 2 Bit 2	HI_LIMIT TEMP	
LO_LIM FB temperature	18	1000 1001	Limit 2 Bit 3	LO_LIMIT TEMP	

Table 13 PROFIBUS communication (continued)

Cause	No. of binary message	Analog input status	Physical Block (PB) Global status	Text of binary message (default)	Logbook (default)
LO_LO_LIM FB temperature	19	1000 1101	Limit 2 Bit 4	LO_LO_LIMIT TEMP	
Logbook empty	20	Function check		EMPTY LOGBOOK	

Section 8 Calibration

8.1 Calibration

Important Note: Use a thermometer to make sure that the displayed temperature is accurate.

Important Note: Enter the sensor data in the configuration menu before calibration.

Important Note: The transmitter must be calibrated each time a new sensor is connected.

Important Note: If measurements are taken in an area with a cross-section < 110 mm, use a calibration beaker with the same size and material (metal/plastic).

Note: Only qualified personnel should conduct the tasks described in this section of the manual.

The transmitter is adjusted to the sensor through the calibration. Use the following methods and passcodes for calibration as described in

Table 14.

Table 14 Methods and passcodes for calibration

Method	Passcode
Display calibration information	0000
Enter cell constant	1100
Calibration with a known calibration solution	0110 ¹
Calibration by product comparison/grab sample	1105 ¹
Zero calibration in air	1001
Zero calibration with calibration solution	
Temperature sensor calibration	1015

1 Not available for Profibus PA and Foundation Fieldbus versions.

During calibration the transmitter remains in the Hold mode for safety reasons. The loop current is frozen at the value specified in the

Calibration

o1.HoLD menu option. The Sensoface icon is inactive. The calibration mode indicator is displayed (**Figure 11 on page 29**).

To exit the calibration mode at any time, press **CAL** and then **ENTER**. The output current will be held for 20 seconds and the measured value will be displayed.

8.1.1 Enter cell constant

1. Press **CAL**, enter passcode: 1100, **ENTER**. CAL CELL will be displayed for 3 seconds.
2. Use the **UP ARROW** and **RIGHT ARROW** to enter the value of the cell constant of the connected sensor. The conductivity value will be displayed also.

***Note:** A cell constant change will change the conductivity value.*

***Note:** If the entry of the cell constant takes longer than 6 seconds, the display will alternate between showing the conductivity and temperature value.*

3. Press **ENTER** to save the value.
4. The transmitter displays the cell constant value and CELL. Press **ENTER**.
5. The transmitter remains in HoLD mode. Press **ENTER** again.

The transmitter remains in HoLD mode for approximately 20 seconds after calibration and returns to the measure mode.

***Note:** Repeat the calibration when "Err" is displayed.*

8.1.2 Calibration with a calibration solution

Use a calibration solution with a known conductivity value to adjust the transmitter to show the same value as the solution.

Note: *Stabilize the temperature during calibration.*

1. Press **CAL**, enter passcode: 0110, **ENTER**. CAL SOL will be displayed for 3 seconds. The transmitter is ready for calibration.
2. Remove and clean the sensor.
3. Immerse the sensor in the calibration solution.
4. Use the **UP ARROW** and **RIGHT ARROW** to enter the known value of the calibration solution.

Note: *If the entry of the calibration solution value takes longer than 6 seconds, the display will alternate between showing the cell constant and the temperature value.*

5. Press **ENTER** to save the value.
6. The display will show the new cell constant. Press **ENTER**.
7. The transmitter remains in HoLD mode. Press **ENTER** again.

The transmitter remains in HoLD mode for approximately 20 seconds after calibration and returns to the measure mode.

The display will show the temperature-corrected value of the calibration solution (unless temperature compensation is set to off in the configuration menu).

Note: *Repeat the calibration when “Err” is displayed.*

Calibration

8.1.3 Calibration by comparison/grab sample

The sensor can be calibrated by measuring the process water with a portable instrument or taking a grab sample and measuring its value in the lab (one-point calibration). The sensor does not need to be removed from the process during calibration. The sample temperature should correspond to the measured process temperature for accurate results.

Note: *The calibration by comparison option is not available when the selected range and units is set to 000.0%.*

1. Press **CAL**, enter passcode: **1105**, **ENTER**. The display will briefly show CAL PRD and then StorE.
2. Measure the process water with a portable instrument or collect a grab sample for measurement in the lab. Press **ENTER** to proceed.
The cal mode indicator will flash to indicate that calibration has not been completed. The transmitter will continue to measure and display the current sample values.
3. Measure the grab sample with a laboratory or portable meter.
4. Press **CAL**, enter passcode: **1105**, **ENTER** to access the product calibration once more. The display will briefly show CAL PRD and then CALC.
5. Edit the displayed value to match the value measured by the laboratory or portable meter and press **ENTER**. The display will show the new cell constant.
6. Press **ENTER** to end the calibration. The display will show the measured value alternating with Hold.

Press **ENTER** to return to the measuring mode. The outputs will remain in the hold mode for approximately 20 seconds.

Note: *For comparison calibration via Foundation Fieldbus, see [section 6.2.4 on page 59](#).*

8.1.4 Zero calibration—air

1. Press **CAL**, enter passcode: 1001, **ENTER**. CAL ZRO will be displayed for 3 seconds.
2. Remove and clean the sensor.

Note: Make sure that the sensor is dry.

3. Use the **UP ARROW** and **RIGHT ARROW** to change the value until zero is displayed as the conductivity value.

Note: If the entry of the zero point value takes longer than 6 seconds, the display will alternate between showing the conductivity value and the temperature value.

4. Press **ENTER** to confirm.
5. The display will show the new cell constant value and the zero point. Press **ENTER** to confirm.
6. Immerse the sensor in the process water.
7. The transmitter remains in HoLD mode. Press **ENTER** again.
The transmitter remains in HoLD mode for approximately 20 seconds after calibration and returns to the measure mode.

Note: Repeat the calibration when “Err” is displayed.

8.1.5 Zero calibration—calibration solution

Use a calibration solution with low conductivity for calibration.

1. Press **CAL**, enter passcode: 1001, **ENTER**. CAL ZRO will be displayed for 3 seconds.
2. Remove and clean the sensor.
3. Immerse the sensor in the calibration solution.
4. Use the **UP ARROW** and **RIGHT ARROW** to change the value until the conductivity value of the calibration solution is displayed.

Calibration

Note: If the entry of the zero point value takes longer than 6 seconds, the display will alternate between showing the conductivity value and the temperature value.

5. Press **ENTER** to confirm.
6. The display will show the new cell constant value and the zero point. Press **ENTER** to confirm.
7. Remove and clean the sensor from the calibration solution.
8. Immerse the sensor in the process water.
9. The transmitter remains in HoLD mode. Press **ENTER** again.
The transmitter remains in HoLD mode for approximately 20 seconds after calibration and returns to the measure mode.

Note: Repeat the calibration when “Err” is displayed.

8.2 Temperature sensor adjustment

1. Press **CAL**, enter passcode: 1015, **ENTER**. CAL TMP will be displayed for 3 seconds. The transmitter is ready for calibration.
2. Measure the process temperature with a thermometer.
3. Use the **UP ARROW** and **RIGHT ARROW** to enter the value of the measured temperature from the external thermometer.
4. Press **ENTER** to save the value.
5. The transmitter remains in HoLD mode. Press **ENTER** again.
The transmitter remains in HoLD mode for approximately 20 seconds after calibration and returns to the measure mode.

Note: Repeat the calibration when “Err” is displayed.

Section 9 Maintenance



DANGER

Explosion hazard. Only qualified personnel should conduct the tasks described in this section of the manual.

DANGER

Electrostatic hazard. Follow the instructions in [Electrostatic Discharge \(ESD\) Considerations on page 17](#) before conducting any maintenance tasks.

9.1 Cleaning the instrument

Use only a moistened antistatic, lint-free cloth to remove dust, dirt and spots from the external surfaces of the transmitter. Use a mild household cleaner if necessary.

9.2 Sensor maintenance

Refer to the user manual supplied with each sensor for specific cleaning requirements.



Maintenance

Section 10 Troubleshooting

10.1 Sensoface

The Sensoface feature is active whenever Sensocheck is active. This feature monitors the sensor for defects in the sensor or cable, and indicates the maintenance status of the sensor (see [Table 15](#)).

Table 15 Sensoface description

Sensoface	Description
	The sensor is operating properly.
	The operation of the sensor is acceptable.
	The sensor is no longer usable. Replace the sensor.

10.2 Sensocheck



The Sensocheck feature monitors the primary and secondary coil for short and open circuits. When problems are detected, the error message “Err 33” (“Err 34”) is displayed, along with an icon corresponding to the type of problem (see [Table 16](#)).

Sensocheck can be switched off during configuration and Sensoface is also disabled.

Note: For confirmation a sensoface is displayed after a calibration setting.

Troubleshooting

Table 16 Error descriptions

Display	Problem	Description
	Sensor is defective	Test the primary (send) coil Test the secondary (receive) coil Refer also to Err 33 and Err 34 (Table 17).
	Temperature error	Make sure that the measured temperature is within the range of the temperature compensation table (temperature compensation, concentration, salinity)

10.3 Error codes

[Table 17](#) describes transmitter errors and parameter-specific errors.

Table 17 Error codes

Code	Description	Corrective action
ERR 01	measured value flashes	Make sure that the entered cell constant is correct.
		Make sure that the range setting is correct.
		Make sure that the SAL value is < 45‰
		Test the sensor connection or replace cables.
ERR 02	measured value flashes	Make sure that the conductance range is < 3000 mS

Troubleshooting

Table 17 Error codes (continued)

Code	Description	Corrective action
ERR 03	Temperature sensor icon flashes; open or short circuit; temperature range exceeded	Test the temperature sensor wiring.
		Make sure that the correct temperature sensor was selected in the configuration menu (GLI/Hach 3700 series sensors use Pt1000).
		Measure the resistance of the temperature sensor in the sensor to make sure of a correct reading. For GLI/Hach 3700 series sensors, the resistance between red and yellow wires should be between 1090–1105 ohms at 23–27 °C.
ERR 11	Current output icon flashes; current is below 3.8 mA	Check the loop power supply voltage to the transmitter.
ERR 12	Current output icon flashes; current is above 20.5 mA	Measure the loop power supply voltage to the transmitter.
ERR 13	Current output icon flashes; reading range value set too large or too small	Make sure that the 4–20 mA output range settings cover a wide enough range and are correct (see section 5.2.1 on page 32)
ERR 33	Sensocheck icon flashes; Sensoface icon active (see section 10.2)	Test the primary (send) coil
	Temperature icon flashes; independent of Sensoface icon (see section 10.2)	Make sure that the temperature is within the range of the temperature compensation table (temperature compensation, concentration, salinity)

Troubleshooting

Table 17 Error codes (continued)

Code	Description	Corrective action
ERR 34	Sensocheck icon flashes; Sensoface icon active (see section 10.2)	Test the secondary (receive) coil
ERR 98	CONF flashes; configuration or calibration data is defective. Memory error in the program.	Reconfigure and calibrate the device.
ERR 99	FAIL flashes; EEPROM or RAM defective	Return to the factory for repair and calibration.

10.4 Diagnostic tests

Function	Description
View the output current	From the measuring mode, press ENTER . The output current will show in the main display for five seconds, then return to measuring mode.
View calibration data	From the measuring mode, press CAL and then enter passcode '0000'. The cell constant will show in the main display. After 20 seconds, the transmitter will return to the measuring mode, or press ENTER to return immediately to the measuring mode.
View sensor monitor for validation	From the measuring mode press CONF and enter passcode '2222' for the validation of the sensor and a complete measured-value processing. The measured resistance is shown in the main display and the measuring temperature is shown in the lower display. Press ENTER to return immediately to the measuring mode.
View the last error message	Press CONF and enter passcode "0000". The last error message is displayed for approximately 20 seconds. CAUTION <i>The transmitter does not go automatically to Hold mode.</i>

10.4 Diagnostic tests (continued)

Function	Description
Specify output current	<p>From the measuring mode, press CONF and enter passcode '5555'. The measured current will show in the secondary display. The output current in the main display can be modified.</p> <p>To change the output current:</p> <ol style="list-style-type: none"><li data-bbox="313 367 964 395">1. Select the current value with the RIGHT ARROW key.<li data-bbox="313 401 964 429">2. Edit the number using the UP ARROW key.<li data-bbox="313 436 964 518">3. Press ENTER to confirm. The entered value will show in the secondary display. The transmitter will remain in Hold mode.<li data-bbox="313 525 964 577">4. To exit Hold mode, press CONF, then ENTER to return to measuring mode.

Section 11 Replacement parts

11.1 si792 transmitter versions

Description	Catalog number
si792(x) E versions (for Hach GLI 3700 series)	
si792x E, inductive conductivity; ATEX Zone 1	LXV503.99.70102
si792(x) T versions (e.g. for 7MA2200 and 8398 series)	
si792x T, inductive conductivity; ATEX Zone 1	LXV502.99.70102

11.2 Accessories

Description	Catalog number
Panel-Mount Installation Kit, si792	LZY484
Pipe-Mount Installation Kit, si792	LZY483
Protective Hood, si792	LZY485

11.3 Replacement parts

Description	Catalog number
Installation Kit, si792,	LZY486
Rear Housing, si792,	LZY487

Replacement parts

Appendix A Calibration solutions

Note: Use the tables in this section to calibrate the transmitter when automatic temperature compensation is set to off.

Table 18 Potassium Chloride solutions (Conductivity in mS/cm)

Temperature		Concentration ¹		
°C	°F	0.01 mol/L	0.1 mol/L	1 mol/L
0	32	0.776	7.15	65.41
5	41	0.896	8.22	74.14
10	50	1.02	9.33	83.19
15	59	1.147	10.48	92.52
16	60.8	1.173	10.72	94.41
17	62.6	1.199	10.95	96.31
18	64.4	1.225	11.19	98.22
19	66.2	1.251	11.43	100.14
20	68	1.278	11.67	102.07
21	69.8	1.305	11.91	104
22	71.6	1.332	12.15	105.94
23	73.4	1.359	12.39	107.89
24	75.2	1.386	12.64	109.84
25	77	1.413	12.88	111.8
26	78.8	1.441	13.13	113.77
27	80.6	1.468	13.37	115.74
28	82.4	1.496	13.62	
29	84.2	1.524	13.87	
30	86	1.552	14.12	
31	87.8	1.581	14.37	
32	89.6	1.609	14.62	
33	91.4	1.638	14.88	
34	93.2	1.667	15.13	
35	95	1.696	15.39	
36	96.8		15.64	

Calibration solutions

1Data source: K. H. Hellwege (Editor), H. Landolt, R. Börnstein: Zahlenwerte und Funktionen ..., volume 2, part. volume 6

Table 19 Sodium Chloride solutions (Conductivity in mS/cm)

Temperature		Concentration		
°C	°F	0.01 mol/L ¹	0.1 mol/L ¹	Saturated ²
0	32	0.631	5.786	134.5
1	33.8	0.651	5.965	138.6
2	35.6	0.671	6.145	142.7
3	37.4	0.692	6.327	146.9
4	39.2	0.712	6.51	151.2
5	41	0.733	6.695	155.5
6	42.8	0.754	6.881	159.9
7	44.6	0.775	7.068	164.3
8	46.4	0.796	7.257	168.8
9	48.2	0.818	7.447	173.4
10	50	0.839	7.638	177.9
11	51.8	0.861	7.831	182.6
12	53.6	0.883	8.025	187.2
13	55.4	0.905	8.221	191.9
14	57.2	0.927	8.418	196.7
15	59	0.95	8.617	201.5
16	60.8	0.972	8.816	206.3
17	62.6	0.995	9.018	211.2
18	64.4	1.018	9.221	216.1
19	66.2	1.041	9.425	221
20	68	1.064	9.631	226
21	69.8	1.087	9.838	231
22	71.6	1.111	10.047	236.1
23	73.4	1.135	10.258	241.1
24	75.2	1.159	10.469	246.2
25	77	1.183	10.683	251.3

Calibration solutions

Table 19 Sodium Chloride solutions (Conductivity in mS/cm)

Temperature		Concentration		
°C	°F	0.01 mol/L ¹	0.1 mol/L ¹	Saturated ²
26	78.8	1.207	10.898	256.5
27	80.6	1.232	11.114	261.6
28	82.4	1.256	11.332	266.9
29	84.2	1.281	11.552	272.1
30	86	1.306	11.773	277.4
31	87.8	1.331	11.995	282.7
32	89.6	1.357	12.22	288
33	91.4	1.382	12.445	293.3
34	93.2	1.408	12.673	298.7
35	95	1.434	12.902	304.1
36	96.8	1.46	13.132	309.5

¹Data source: Test solutions calculated according to DIN IEC 746-3

²Data source: K. H. Hellwege (Editor), H. Landolt, R. Börnstein: Zahlenwerte und Funktionen ..., volume 2, part. volume 6

Calibration solutions

Appendix B Concentration curves

B.1 Concentration measurement ranges

For the solutions listed in [Table 20](#), the transmitter determines the concentration from the measured conductivity and temperature values in % by weight.

The measurement error is made up of the sum of measurement and the stored accuracy of the concentration curves.

Note: *The transmitter must be calibrated each time a new sensor is connected.*

Note: *Calibrate a temperature sensor adjustment for a correct temperature measurement.*

Note: *Use a separate temperature sensor with fast response for measuring processes with rapid temperature changes.*

Concentration curves

Table 20 Concentration ranges

Substance	Solution	Range (% by weight)	Temperature
NaCl	-01-	0–26%	0 °C
		0–28%	100 °C (212 °F)
HCl	-02-	0–18%	–20 °C (–4 °F)
		0–18%	50 °C (122 °F)
	-07-	22–39%	–20 °C (–4 °F)
		22–39%	50 °C (122 °F)
NaOH	-03-	0–13%	0 °C (32 °F)
		0–24%	100 °C (212 °F)
	-10-	15–50%	0 °C (32 °F)
		35–50%	100 °C (212 °F)
H ₂ SO ₄	-04-	0–26%	–17 °C (1.4 °F)
		0–37%	110 °C (230 °F)
	-09-	28–88%	–17 °C (1.4 °F)
		39–88%	115 °C (239 °F)
	-06-	94–99%	–17 °C (1.4 °F)
		89–99%	115 °C (239 °F)
HNO ₃	-05-	0–30%	–17 °C (1.4 °F)
		0–30%	50 °C (122 °F)
	-08-	35–96%	–20 °C (–4 °F)
		35–96%	50 °C (122 °F)

Concentration curves

B.2 Sodium chloride solution -01- NaCl

Refer to **Figure 14** for the conductivity of sodium chloride solution at various concentrations and temperatures.

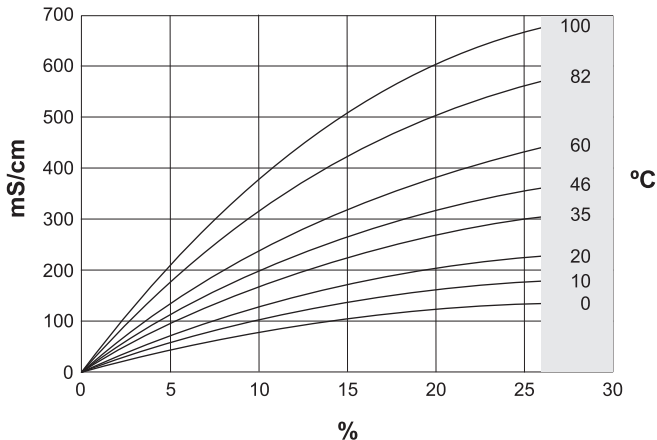

Figure 14 The concentration of sodium chloride solution -01- NaCl (weight %)

Note: Concentration measurement not possible in the gray shaded range.

Concentration curves

B.3 Hydrochloric acid -02- HCl

Refer to **Figure 15** for the conductivity of hydrochloric acid (HCl) at various concentrations and temperatures.*

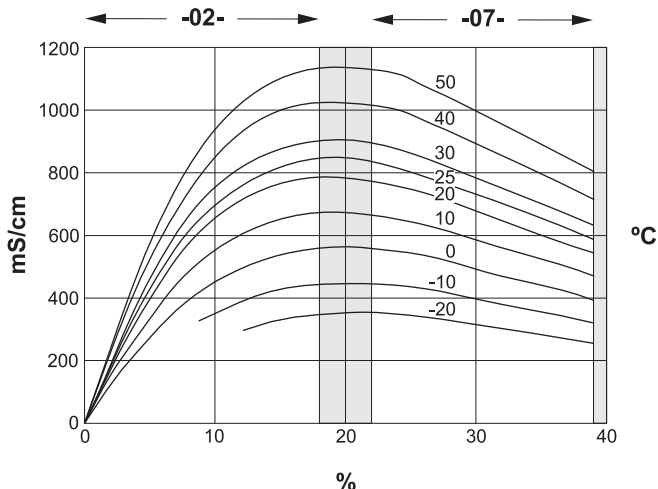

Figure 15 The concentration of hydrochloric acid -02- and -07- HCl (weight %)

Note: Concentration measurement not possible in the gray shaded range.

* Source: Haase/Sauermann/Dücker; Z. phys. Chem. New Edition, Vol. 47 (1965)

Concentration curves

B.4 Sodium hydroxide solution -03- NaOH

Refer to **Figure 16** for the conductivity of sodium hydroxide solution (NaOH) at various concentrations and temperatures.

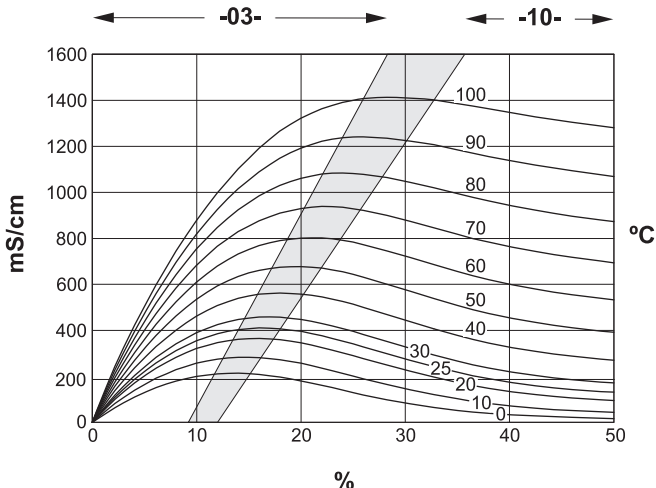

Figure 16 The concentration of sodium hydroxide solution -03- and -10- NaOH (weight %)

Note: Concentration measurement not possible in the gray shaded range.

Concentration curves

B.5 Sulfuric acid -04- H_2SO_4

Refer to **Figure 17** for the conductivity of sulfuric acid at various concentrations and temperatures.*

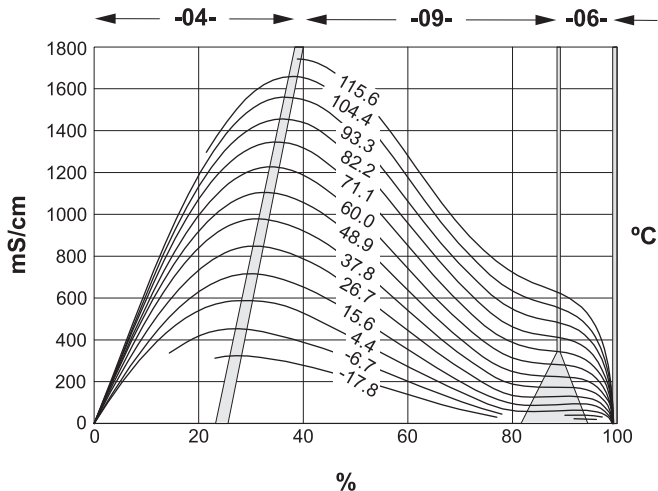

Figure 17 The concentration of sulfuric acid -04-, -09- and -06- H_2SO_4 (weight %)

Note: Concentration measurement not possible in the gray shaded range.

* Source: Darling; Journal of Chemical and Engineering Data; Vol.9 No.3, July 1964

Concentration curves

B.6 Nitric acid -05- HNO₃

Refer to **Figure 18** for the conductivity of nitric acid at various concentrations and temperatures.*

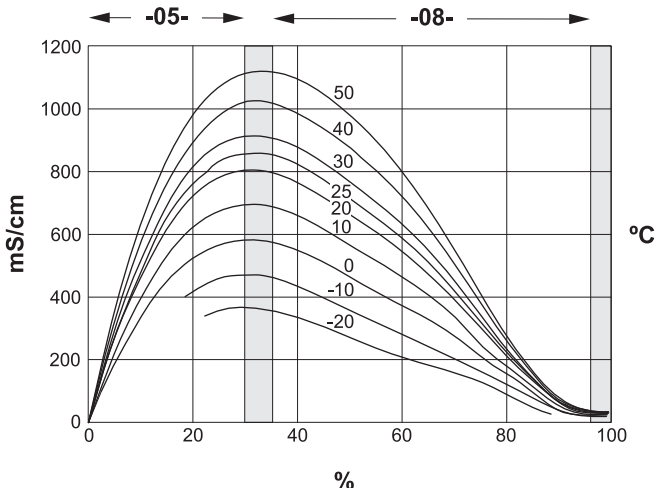

Figure 18 The concentration of nitric acid -05- and -08- HNO₃ (weight %)

Note: Concentration measurement not possible in the gray shaded range.

* Source: Haase/Sauermann/Dücker; Z. phys. Chem. New Edition, Vol. 47 (1965)

Concentration curves

Appendix C Passcode editor

For applications requiring compliance to FDA 21 CFR Part 11, certain device functions must be protected with passcodes. Passcodes can be changed in the passcode editor. If passcode protection is not required, use the preset passcodes ([Table 21](#)).

To activate the passcode editor:

1. Press **CONF**.
2. Enter **1989**, the administrator passcode. The initial screen will show for approximately 3 seconds, then proceed to the next function.
3. Use the **ARROW** keys to change the passcode.
4. Press **ENTER** to proceed to the next function. Press **CONF** to exit the passcode editor. Refer to [Table 21](#) for default passcodes.

Table 21 Default passcode settings

Display	Function	Default setting
Cal INFO	Calibration information	0000
CAL 0-CAL	Calibration zero	1001
CAL CELL	Calibration—cell factor adjustment	1100
CAL SOL	Calibration with standard solution	0110 ¹
CAL PROD	Product calibration	1105 ¹
CAL RTD	Temperature sensor adjustment	1015
CFG ERR	Error information	0000
CFG CONF	Configuration mode	1200
CFG SNSR MO	Sensor monitor	2222
CFG OUT	Current source	5555 ¹
CFG SPCL ST	Administrator passcode. Use ARROW keys to select NO or YES	1989
NO SPCL ST	Do not change administrator passcode	Press ENTER to return to the default passcode
		Press CONF to exit the editor

Passcode editor

Table 21 Default passcode settings

Display	Function	Default setting
YES SPCL ST	Change administrator passcode	Press ENTER to accept the new passcode
		Press CONF to exit the editor

1 Not available for the Profibus PA and Foundation Fieldbus versions.

Important Note: *The passcode editor cannot be accessed without the administrator passcode. Record changes in a secure location. It is not possible to override this system if the passwords are lost. The unit must be exchanged. Contact technical support for assistance.*

Appendix D ATEX safety instructions

The following ATEX safety instructions pertain to the electrodeless conductivity sensors, model 3700E-series, types 3708E2T, 3727E2T and 3728E2T manufactured by Hach Company. These sensors are described in the EC type-examination certificate TÜV 07 ATEX 553601 as part of the Transmitter si792x E.

The operating manual for the transmitter si792x E is expanded with the operating manual *Model 3700E-Series Electrodeless Conductivity Sensors* (doc number MAN-3700E) and with the ATEX safety instructions. Both documents are shipped with the model 3700E sensors.

For the safe usage, mounting and installation, commissioning, maintenance and de-installation of the sensors, the information in the operating manual *Model 3700E-Series Electrodeless Conductivity Sensors* (doc number MAN-3700E) and the following information are to be noted and followed as per Annex II, 1.06 of the directive 94/9/EC.

1. The model 3700E sensors are intended to be used for measuring and processing electrochemical parameters. For this purpose the sensors are equipped with a circuit for the conductivity measurement and with a circuit for the temperature measurement. ONLY the types 3708E2T, 3727E2T and 3728E2T sensors are intended to be used in areas endangered by explosive atmospheres and for which equipment in group II, equipment category 1, gas, is necessary.
2. ONLY the types 3708E2T, 3727E2T and 3728E2T sensors are only allowed to be operated together with the Transmitter si792x E, see EC type-examination certificate TÜV 07 ATEX 553601. Operation of the sensors with the Transmitter si792x T is not allowed.
3. The types 3708E2T, 3727E2T and 3728E2T sensors are intended for usage in specific environmental conditions. These and other conditions are listed in the operating manuals *Model 3700E-Series Electrodeless Conductivity Sensors* and the "ATEX Safety

ATEX safety instructions

Instructions" and comprise information on the environmental conditions, on installation/setting up and commissioning, on correct operation (= usage), on assembly and de-installation, on maintenance.

4. Attention is to be paid to the action of moisture, ambient temperature and chemicals. The instruction manual contains an overview, in tabular form, of the chemical resistance of the housing materials PFA Teflon and PEEK. If it is not possible to derive a clear assessment from this information, then more detailed tables are to be used. If it is still not possible to perform a clear assessment on safe usage, or applications areas other than those described are intended, then the application must be clarified with Hach Company/Hach Lange GmbH.
5. A condition for the safe usage of sensors is compliance with the stated environmental conditions and temperature ranges.
6. Due to the mechanical dimensions and the materials used, in certain process conditions such as dry environments or gas streams, hazards may arise due to electrostatic charging that could produce sparks capable of ignition when discharged. It is therefore necessary to comply with the following (refer to **Figure 19**):
 - The sensors are only allowed to be used in media with a conductivity $> 1 \text{ nS/m}$.
 - The sensors are only allowed to be used in media with a flow velocity $< 2 \text{ m/S}$.
 - The $5/8\text{-}11\text{UNC}$ metal fitting must be earthed.
7. ONLY the types 3708E2T, 3727E2T and 3728E2T sensors are intended for operation in intrinsically safe "ia" circuits and for mounting in the boundary wall between zone 0 and the less endangered area. They are equipped with an industrial self-sealing $3/4\text{-inch}$ NPT process connection or with an industrial plumbing connection with 2-inch flange and EPDM seal (compliant with 3-A

ATEX safety instructions

plumbing standard) (refer to **Figure 19**). Mounting in the boundary wall between zone 0 and the less endangered area is to be undertaken properly such that an adequately sealed gap (IP 67) is obtained.

8. The model 3700E sensors have been developed and manufactured in compliance with the applicable European directives and standards.
9. Compliance with the European directives and standards is confirmed by the CE declaration of conformity. Compliance with the harmonized European standards for usage in areas endangered by explosive atmospheres is confirmed by the EC type-examination certificate. The CE declaration of conformity and the EC type-examination certificate are part of the operating manuals.
10. On the usage of the types 3708E2T, 3727E2T and 3728E2T sensors, the stipulations for electrical apparatus for explosive gas atmospheres, IEC 60079-14 and EN 1127-1 must be met. In the event of installation outside the scope of directive 94/9/EC, the locally applicable stipulations are to be taken into account.
11. A specific, direct hazard is not caused by the use of the equipment on usage in the stipulated environmental conditions.

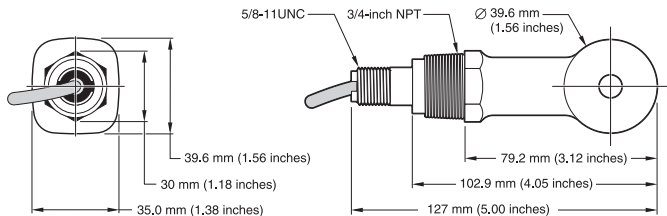

Figure 19 Convertible-style sensor

ATEX safety instructions

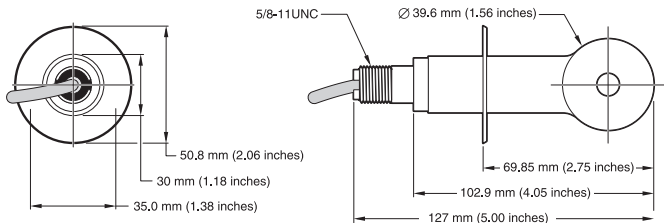

Figure 20 Sanitary-style sensor

22 mA signal	35
4–20 mA output	
error notification	35
A	
assembly	
transmitter	15
audit trail	12
C	
calibration	67
by product comparison	70
methods	67
passcodes	67
solutions	83
cleaning the transmitter	73
components	14
concentration	
curves	87
measurement	35
range	35
configuration	
alarm	38
current output	32, 40, 62
overview	31
temperature	37
curves	
concentration	87
D	
diagnostic functions	78
dimensions	16, 17
display	29

Index

E	
electrostatic discharge (ESD)	17
error codes	76
F	
FDA compliance	12
H	
hold mode	
during configuration	34
during output	36
I	
icons	29
L	
LED	
setting on or off during hold	38
M	
measurement mode	31
menu navigation	34
N	
navigation, menu	34
P	
passcodes	
description	12
S	
safety information	
general	9
wiring	17
Sensocheck	
description	75
setting on or off	38

Sensoface	75
solutions	
calibration	83
symbols, display	29

T

temperature compensation	37
temperature probe adjustment	72
troubleshooting	78

W

wiring

7MA2200 sensors	24
8398 sensors	25
diagram	19
GLI 3700 sensors	23
HART communicator	26
power	21, 22
sensor	22

Index

HACH COMPANY World Headquarters

P.O. Box 389, Loveland, CO 80539-0389 U.S.A.
Tel. (970) 669-3050
(800) 227-4224 (U.S.A. only)
Fax (970) 669-2932
orders@hach.com
www.hach.com

HACH LANGE Sàrl

6, route de Compois
1222 Vézenaz
SWITZERLAND
Tel. +41 22 594 6400
Fax +41 22 594 6499

HACH LANGE GMBH

Willstätterstraße 11
D-40549 Düsseldorf
Tel. +49 (0) 2 11 52 88-320
Fax +49 (0) 2 11 52 88-210
info-de@hach.com
www.de.hach.com

